



BOSNIA AND HERZEGOVINA
STATE ELECTRICITY
REGULATORY COMMISSION



ANNUAL REPORT 2025



Bosnia and Herzegovina
STATE ELECTRICITY REGULATORY COMMISSION

**REPORT ON ACTIVITIES
OF THE STATE ELECTRICITY REGULATORY COMMISSION
IN 2025**

Tuzla, December 2025

Report on Activities of the State Electricity Regulatory Commission follows the reporting approach of regulatory authorities in the European Union and Energy Community requirements, with some adaptations reflecting the characteristics of the regulatory framework in Bosnia and Herzegovina.

Any user is required to cite the source if using data from this report.

“Complex problems can and should be solved by breaking them down into a series of elementary steps.”
Al-Khwarizmiⁱ

ⁱ Al-Khwarizmi, *Al-Kitāb al-Mukhtaṣar fī Ḥisāb al-Jabr wal-Muqābalah* (translated: *The Compendious Book on Calculation by Completion and Balancing*, Latin: *Liber Algebrae et Almucabola*), usually abbreviated as *Al-Jabr* or *Algebra*, is a work dating to around 820, from which algebra takes its name. Al Khwarizmi is credited with introducing Hindu-Arabic numerals into practical use. The word *algorithm* comes from the word *Algoritmi*, a Latin transcription of his name.

Contents

1.	INTRODUCTION	1
2.	COMPOSITION AND ORGANISATION OF WORK OF THE COMMISSION	3
3.	KEY ACTIVITIES	7
3.1	SERC Rules and Documents.....	7
3.2	Documents Approved by SERC.....	15
3.3	Licensing and Preliminary Permit Issuance Proceedings	24
3.4	Monitoring of Activities of Licensed Entities.....	26
3.5	Technical Aspect of Transmission System Operation	29
3.6	Tariff Proceedings	35
3.7	Electricity Market.....	38
3.8	Energy Statistics.....	53
3.9	Judicial and Other Disputes	56
3.10	Other Key Activities	56
4.	ACTIVITIES IN INTERNATIONAL INSTITUTIONS	59
4.1	Energy Community	59
4.2	Energy Regulators Regional Association – ERRA	65
4.3	Mediterranean Energy Regulators – MEDREG.....	67
4.4	Balkan Energy School – BES	68
4.5	Council of European Energy Regulators – CEER	68
4.6	International Confederation of Energy Regulators – ICER.....	69
5.	AUDIT REPORT	71
6.	MAIN ACTIVITIES IN 2026	73
ANNEXES		
A:	Basic Data on the Electric Power System of Bosnia and Herzegovina	77
B:	Map of the Electric Power System of Bosnia and Herzegovina	79
C:	Balance Values of the Electric Power Sector of Bosnia and Herzegovina	81
D:	Electric Power Indicators of Bosnia and Herzegovina	83
E:	Energy Community <i>Acquis</i>	85

1. INTRODUCTION

The energy systems of the European Union and the Energy Community Contracting Parties are undergoing a profound transformation, driven by the imperatives of decarbonisation, digitalisation and structural reform of the energy sector. In this dynamic environment, operational solutions need to enable better flexibility and ensure the efficiency and resilience necessary for a sustainable energy future.

Artificial intelligence is increasingly recognised as a useful tool in developing new ideas, creating solutions and original content that may encourage innovations in various fields, including the electric power industry. However, using its full potential requires navigating the complex interaction of technological development, policy frameworks, ethical principles and cooperation among stakeholders.

The energy transition implies the optimal and comprehensive use of the electricity system. Weather-dependent generation, the need for active demand side management and market integration lead to more intensive use of the network. In this context, the establishment of operational prerequisites for system optimisation and a single European electricity market becomes the priority.

A number of interconnected challenges with multidimensional complexity are still present in the energy sector of Bosnia and Herzegovina (BIH), requiring significant changes in the pace and present mode of operation. At all administrative levels in Bosnia and Herzegovina, in line with respective constitutional competences, it is necessary to continue the alignment and implementation of energy legislation with the European Union and Energy Community *acquis*. Against this background, it is necessary to take brave and sound decisions without further delay.

In 2025, the State Electricity Regulatory Commission (SERC) continued its regulatory mission in the sector, developing the conditions for unhindered trade in electricity and reliable electricity supply. This Annual Report also highlights regular regulatory activities, including the adoption of secondary legislation, approval of documents proposed by the regulated entities, licensing and tariff-setting procedures, regulatory monitoring of operations of the licensed entities, as well as monitoring of the electricity market functioning and technical parameters of the electricity system. In the past year, SERC continued to cooperate with a large number of institutions of Bosnia and Herzegovina, its Entities and the District as well as numerous international institutions whose work pertains to the electricity sector.

The electricity system of Bosnia and Herzegovina operated steadily and without major problems during the past year. All system users were able to operate functionally in line with the defined quality standards. All planned and subsequently requested maintenance works in the transmission network were fully completed.

The State Electricity Regulatory Commission is an independent institution of Bosnia and Herzegovina, which acts in accordance with the principles of objectivity, transparency and non-discrimination, and has jurisdiction over and responsibility for the transmission of electricity, transmission system operation and international trade in electricity, as well as generation, distribution and supply of electricity for customers in the Brčko District of Bosnia and Herzegovina.

SERC is a non-profit institution and is financed by regulatory fees, which are paid by the licensed entities.

Several contracts on the construction of transmission facilities have been implemented, which further increased the security and reliability of supply for customers. A number of new substations were put into operation, enabling the connection and commissioning of new renewable generation facilities – solar photovoltaic and wind power plants.

Electricity generation in the reporting year totalled 14,540.2 gigawatt hours (GWh), which is a decrease of 13.4 GWh compared with 2024. The extremely unfavourable hydrological conditions were reported for the second year in a row, which resulted in a 6.3% decrease of generation by the major hydropower plants amounting to 4,432.6 GWh. Generation by thermal power plants amounted to 7,933.9 GWh, which is the lowest value since 2006. At the same time, a significant increase in renewable generation was recorded. Generation by wind power plants increased by 65.1% amounting to 648.4 GWh while solar power plants connected to the transmission system increased generation by 127% reaching 474.2 GWh. Small-scale renewable generation (small hydropower plants, wind, solar and biofuel power plants connected to the distribution system) increased by 46.8% amounting to 1,042.4 GWh. Industrial power plants produced 8.6 GWh.

Total electricity consumption amounted to 12,330.4 GWh, which is a 1.6% increase compared with the previous year. More than half of it (53.5%) was supplied by renewable generation which totalled 6,597.6 GWh. Consumption by customers connected to the transmission system decreased by 24.4% amounting to 650.1 GWh, while consumption by customers connected to the distribution network increased by 3.2% reaching 11,252.2 GWh.

The maximum hourly load of the power system in the previous year amounting to 2,209 megawatts (MW) was reported on 31 December 2025 at the 18th hour. This exceeded the previous historic maximum of 2,207 MW reported at the same hour and day in 2014. The minimum hourly load of 591 MW was reported at the 14th hour on 14 May 2025, which is 6 MW less than the previous lowest hourly load in the past several decades, recorded at the 4th hour on 12 June 2023.

Total electricity in the transmission network amounted to 18,126.1 GWh, which is 1.83% less than in 2024. Transmission losses amounted to 350.0 GWh, or 1.93% of total energy in the transmission system. In 2025, distribution losses amounted to 914.6 GWh or 8.13% in relation to total consumption by customers connected to the distribution network, which is the lowest level in the history of the power sector of Bosnia and Herzegovina.

In 2025, electricity exports amounted to 5,137 GWh, which is 13.5% more than in the previous year. At the same time, imports increased by 39.0% amounting to 2,810 GWh.



The State Electricity Regulatory Commission was established by the Parliamentary Assembly of Bosnia and Herzegovina by adoption of the Law on Transmission of Electric Power, Regulator and System Operator of BiH, and by appointment of the Commissioners.

2. COMPOSITION AND ORGANISATION OF WORK OF THE COMMISSION

The Commissioners from the Federation of Bosnia and Herzegovina are:

- Mr. Suad Zeljković, with a five-year term (from 11 June 2016), and
- Mr. Nikola Pejić, with his second five-year term (from 11 June 2016).

The Commissioner from the Republika Srpska is

- Mrs. Branislava Milekić, with a five-year term (from 5 August 2020).

It is evident that the second five-year term of one Commissioner from the Federation of Bosnia and Herzegovina expired and that the first five-year term of the other Commissioners expired. Taking into consideration that the *Law on Transmission of Electric Power, Regulator and System Operator of BIH* sets forth that the Commission can only operate with all three commissioners and make decisions by a unanimous vote, Mr. Suad Zeljković, Mr. Nikola Pejić and Mrs. Branislava Milekić continue to perform the function of Commissioners until the completion of the procedure for appointment of the Commissioners in accordance with the Law.¹

Since the establishment of the State Electricity Regulatory Commission, the Commissioners rotate in the position of the Chairperson equally on an annual basis. Until 30 June 2025, this function was performed by Mrs. Branislava Milekić. Mr. Suad Zeljković is the current Chairman of the Commission until 30 June 2026.

In line with the Law, SERC was established as an independent institution of Bosnia and Herzegovina, with the obligation to act in accordance with the principles of objectivity, transparency and non-discrimination. These principles have been incorporated in all SERC documents and implemented in all procedures. This method of operation takes into consideration the international examples of good practice and the content of the *Policy Guidelines of the Energy Community Secretariat on the Independence of National Regulatory Authorities*. Incorporated in rules and continuously implemented in practice, the independence of SERC has been shown and demonstrated in all areas including political, legal, social and financial dimensions.

The European Union energy *acquis*, which becomes mandatory for BIH in line with the mechanisms established under the *Stabilisation*

¹ At the time of the creation of this report, the procedure of electing the two Commissioners from the Federation of Bosnia and Herzegovina was in the process before the Parliamentary Assembly of Bosnia and Herzegovina. It was preceded by a proposal put forward by the Government of the Federation of BIH, which was then confirmed by the Parliament of the Federation of BIH. In February 2023, the Council of Ministers of Bosnia and Herzegovina proposed the appointment of Commissioners to the Parliamentary Assembly of Bosnia and Herzegovina. The House of Representatives adopted the Decision on the appointment of Commissioners of the State Electricity Regulatory Commission from the Federation of BIH at its 4th session held on 23 February 2023.



Report on Activities of the State Electricity Regulatory Commission in 2024 was submitted to the Parliamentary Assembly of Bosnia and Herzegovina (PABIH) on 27 March 2025.

The Report was unanimously accepted at the 15th session of the Committee on Foreign and Trade Policy, Customs, Traffic and Communications of the House of Peoples of PABIH and at the 26th session of the Committee on Traffic and Communications of the House of Representatives of PABIH, which were held on 14 April 2025.

The Report was considered and adopted at the 27th session of the House of Representatives held on 15 April 2025. The House of Peoples of PABIH did not consider the submitted report at its sessions in 2025.

and Association Agreement and the Treaty establishing the Energy Community, especially highlights the correlation between the regulatory independence and reform implementation and introduces expanded powers of the regulators.

Pursuant to the Law, the basic provisions on competence, organisation and method of work, financing, transparency and the protection of confidential data are regulated by the *Statute of the State Electricity Regulatory Commission* which was adopted in 2003, immediately after the establishment of SERC, and amended in 2004, 2009 and 2017. The Statute clearly prescribed the exclusive organisational and ceremonial role of the Chairperson of the Commission without any additional powers in presenting, representing or decision-making in relation to the other two Commissioners.

The work of SERC is organised within four departments:

- Tariff and Market Department,
- Licensing and Technical Affairs Department,
- Legal Department, and
- Financial and Administrative Department.

With the aim of performing its tasks in a more efficient manner, task forces are formed on a needs basis at SERC in the work of which employees from different departments participate.

The objectives of the key business processes within the competence of each organisational units create the basis for the development of the internal financial management and control system based on risk management. Through education and instructions provided by the Central Harmonisation Unit of the Ministry of Finance and Treasury of Bosnia and Herzegovina (CHU) the implementation of the measures included in the strategic documents of Bosnia and Herzegovina in this field continued. A significant part of the planned activities, included in the Action Plan for Improvement of Internal Financial Control System for 2024, was successfully implemented. After a review of the Risk Register, which was established in 2021 for the first time, and an analysis of the effects of the implementation of adopted procedures, the previous assessment of the exposure to the risks for SERC activities was kept. The most relevant risks were ranked medium in priority.

Intensified digital communication stressed the importance of equipment reliability and the enhanced protection of information-communication systems. In compliance with the relevant standards and guidelines of the Council of Ministers of BIH, in 2025 SERC replaced part of computer equipment with the new one while taking into consideration the energy characteristics of the equipment and good practice as recommended by the Audit Office of the Institutions of Bosnia and Herzegovina in its performance audit reports.

Electronic communication tools were also used in improving knowledge and experience of the staff, that is, capacity building, enabling





SERC to follow the requirements of regulatory practice. The improvement of knowledge is achieved in different professional symposiums, conferences and thematic seminars. In addition, systematic training aimed at continuous harmonisation of knowledge, skills and practice with the needs and expectations of the institution is provided by specialised workshops of the Energy Community, training programs of the Energy Regulators Regional Association (ERRA), the Mediterranean Energy Regulators (MEDREG), the Balkan Energy School (BES) and the Council of European Energy Regulators (CEER). Contribution to professional training was also provided through the project of the United States Government – Energy Policy Activity (EPA) and activities of the German Agency for International Cooperation (*Deutsche Gesellschaft für Internationale Zusammenarbeit – GIZ*) in the region and Bosnia and Herzegovina.

SERC will remain dedicated to ensuring continuous professionalism of human resources through the well-established as well as new education methods. The justification of this approach is also confirmed by communication and presentation competence of the employees who successfully present their knowledge and experience at national and international professional gatherings. In addition to professional training of its employees, SERC informed and shared its experiences on regulatory practice in a proper manner with regulated companies' employees, and participated in professional training of staff of other regulatory authorities in the world. Furthermore, SERC provided quality professional information on the energy sector not only to specialists in the sector but also to the wider public.

Acknowledging the importance of free access to information as a fundamental characteristic of transparent and accountable action by any public authority, and remaining committed to acting along these lines on a permanent basis, SERC allows the wider public to have a full insight into its work and decision-making processes, going beyond the mandatory framework in this field stipulated by the *Law on Freedom of Access to Information in Bosnia and Herzegovina*. SERC fulfils these commitments by publishing all relevant information on its official website in a timely manner, including also print media, through the presentation of SERC drafts documents, as well as notices and invitations to the public to participate in the creation thereof.

In addition to a proactive approach as the generally accepted standard in its activities, SERC also acts reactively, handling submitted requests for access to information within the legally prescribed deadlines, starting from the position that in any concrete case the public interest must prevail over the constraints stipulated by the mentioned Law and any private interest. *The Report of the State Electricity Regulatory Commission on the Implementation of the Law on Freedom of Access to Information at the Level of the Institutions of Bosnia and Herzegovina in 2025* puts a particular emphasis on the fact that only one request of this kind was submitted in the previous year. However, a significant number of journalist

inquiries were submitted requesting various data from the energy sector or opinions and positions on the current topics, which were answered on the same or the next day at the latest. SERC will also meet other obligations stipulated by the mentioned law in compliance with the required deadlines and acts adopted by the Council of Ministers of BIH and continue its practice of reporting to all relevant institutions in the required manner.

Communication with the public plays a key role in creating perceptions, that is, the ways for the public to understand how institutions function. The method of communication is of particular importance in the period of reforms and structural changes. In the process of sector liberalisation and transition, deregulation and electricity market opening it is necessary both to inform the public in a timely manner of the major phases and to continuously communicate with all key stakeholders about the reform and educate them about the way the sector as a whole functions.

It is good practice of regulatory commissions to implement public outreach activities to explain and clarify the changes in the energy sector. In line with this, the State Electricity Regulatory Commission, the Regulatory Commission for Energy in the Federation of BIH (FERK) and the Regulatory Commission for Energy of Republika Srpska (RERS), which as unbiased organisations protect the interests of customers by regulating relationships in the sector and electricity market, have a key role also in Bosnia and Herzegovina in raising awareness of the changes in the sector and regulators' activities in the liberalisation process. In 2025, the State Electricity Regulatory Commission continued to act in accordance with its *Communications and Public Outreach Plan*, thus making an additional step forward in order to explain very complex energy sector topics in a simple and comprehensible way to all interested parties.

Large volumes of different documents are created as a result of SERC activities. The number of documents and information has been constantly increasing. SERC, as the creator, organises the keeping, evaluation, extraction and protection of the registry office material under the professional supervision of the Archive of Bosnia and Herzegovina. This cooperation enables these processes to develop in line with professional principles, experiences and recommendations and through mutual familiarisation of the two institutions.

In the reporting period, SERC used the possibility of applying a modern method of organising office management in its work, and in compliance with the prescribed standards and rules of the Council of Ministers of BIH, continued using an electronic records management system. In addition to the efficient entry and search of data as well as archiving a large number of documents in the digital form, the introduced system created the prerequisites for modern business process management and the integration with other business systems. In this process, good practice as recommended by the Audit Office of the Institutions of Bosnia and Herzegovina in its performance audit reports was taken into consideration.

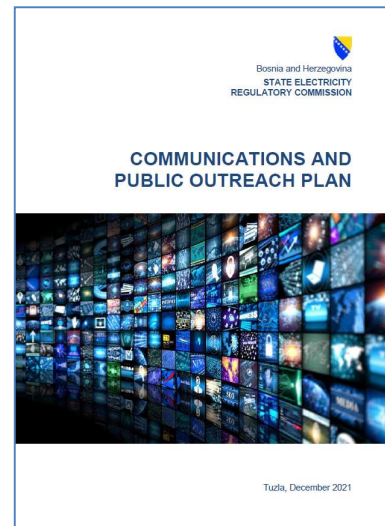

3. KEY ACTIVITIES

In 2025, the State Electricity Regulatory Commission held 21 regular sessions, 27 internal meetings and organised 18 public hearings, of which 15 were of general and 3 of formal nature.

In the reporting period, in a transparent manner and by holding relevant public hearings in which interested members of the public were allowed to give their comments along with power sector stakeholders, the Commission conducted the activities with regard to adoption and approval of a range of documents, tariff-setting, granting of licences, and carried out other activities of which the most important ones are grouped in the clusters provided below.

Transparency towards the public through consultation and communication with all interested professionals, as well as the wider public, is the fundamental orientation of the Commission, which is conducive to checking the suitability of proposed solutions before their final adoption. The practice of the mutual exchange of collected public comments in the same or similar procedures is applied by all three regulatory authorities in the energy sector of Bosnia and Herzegovina.

Documents under regulatory competences are reviewed and defined in regular sessions of the State Electricity Regulatory Commission, in accordance with the authorities prescribed by the law; issues and documents of an organisational and administrative nature are reviewed and adopted in internal meetings.

With a view to soliciting comments of interested parties and members of the public on rules and regulations, or on any other document, SERC organises general public hearings. With a view to resolving technical issues during the proceedings and processing of procedural or essential issues, technical public hearings are held. With a view to establishing decisive facts, based on which SERC may resolve certain applications or disputes, formal public hearings are held.

Regular sessions and all public hearings are open to the public.

3.1 SERC Rules and Documents

Connection Rules

The State Electricity Regulatory Commission adopted new *Connection Rules* on 17 October 2025. This document prescribes the procedure for connection of a new facility of a generator, of a customer, an electricity storage facility or a hybrid facility² to the transmission network at 400, 220 and 110 kV voltage level, connection of facilities to 35, 20, 10 and 6 kV medium voltage level at 110/x kV substations of the Transmission Company, as well as connection of an existing facility in case of an increase in connected capacity, upgrade or reconstruction of facilities.

In the previous period the need for updating Connection Rules was recognised, particularly in light of the interest and the need for investments in renewable sources and electricity storage facilities. The realisation of the expressed public interest in the construction and expansion of users' generation and transmission capacities prompted the involvement of a larger number of entities in the preparation of appropriate procedures for connecting these capacities to the BIH electricity transmission network, which is managed, maintained, built and expanded by the Company for the Transmission of Electric Power – *Elektroprenos Bosne i Hercegovine*. A general public hearing in the procedure for adoption of this documents was held on 24 July 2025. On this occasion, various

² Hybrid facility means a facility for generation and/or consumption of electricity which combines multiple different technologies including also an electricity storage facility, and which is connected to the same access point to the network.

interests and views on the methods and conditions of connection were presented.

The State Electricity Regulatory Commission harmonised to the greatest extent possible the text of Connection Rules with definitions and key provisions of the *Network codes and guidelines*,³ primarily *Connection Codes*, which include the following regulations:

- Commission Regulation (EU) 2016/631 of 14 April 2016 establishing a network code on requirements for grid connection of generators,
- Commission Regulation (EU) 2016/1388 of 17 August 2016 establishing a Network Code on Demand Connection, and
- Commission Regulation (EU) 2016/1447 of 26 August 2016 establishing a network code on requirements for grid connection of high voltage direct current systems and direct current-connected power park modules.

Network codes and guidelines are technical rules adopted with the aim of establishing joint rules for the reliable system operation, and market functioning and integration. These legal acts are the key element for efficient functioning of a pan-European market which puts electricity customers at the forefront. They supplement the existing *acquis* of the European Union and are directly applicable in the EU Member States.

Decisions of the Ministerial Council and the Permanent High Level Group (PHLG) expanded the Energy Community *acquis* (legal framework), to include, with the relevant adaptations the previously mentioned Connection Codes, as well as *Market Codes* – three Commission regulations and *System Operation Codes* – two Commission regulations.

Tariff Pricing Methodology for Services of Electricity Transmission, Operation of an Independent System Operator and Ancillary Services

Continuing its activities related to the tariff rules development, on 24 September 2025 the State Electricity Regulatory Commission adopted the *Tariff Pricing Methodology for services of electricity transmission, operation of an independent system operator and*

³ Harmonisation, that is, unambiguous regulation of a whole set of rules for network operation was recognised in the European Union Third Energy (please see Article 6 of Regulation (EC) No 714/2009, that is, Regulation (EC) No 715/2009). In line with this, the EU Member States, with full participation of the Agency for the Cooperation of Energy Regulators (ACER), the European Network of Transmission System Operators for Electricity (ENTSO-E) and the European Network of Transmission System Operators for Gas (ENTSO-G) conducted a complex activity of developing codes and guidelines for operation of networks (*Network Codes*).

The set of these codes in the electricity sector includes codes on market, system operation, connection and cybersecurity, which were described in detail in the previous SERC report on activities.





“Due to the lack of transposition of the acquis into the laws, SERC currently lacks the necessary competencies to implement the Energy Integration Package (EIP)... BIH is urged to transpose the Energy Community acquis, including the EIP... SERC should be empowered to adopt regulatory rules for market integration, including in natural gas.”

(From Annual Implementation Report of the Energy Community Secretariat, Vienna, 1 November 2025)

ancillary services. The Methodology defines the tariff structure and tariff pricing method for services of electricity transmission, operation and the system service of an independent system operator and the tariffs for ancillary services.

The Methodology is based on the traditional rate-making method (*cost of service regulation*) in which the regulator approves a revenue requirement to a regulated company sufficient to cover justified costs. The application of the Methodology ensures that approved tariffs are transparent, non-discriminatory and based on justified operation and maintenance costs (cost reflected), that they promote energy efficiency, create stable relationships on the electricity market and promote the regulated activity development, take into consideration the environment protection and reflect the standards common in international practice.

A general public hearing in the procedure for adoption of the Methodology was held on 29 July 2025. The content of the Methodology was harmonised to the greatest extent possible with the content of the following *Market Codes*:

- Commission Regulation (EU) 2015/1222 of 24 July 2015 establishing a Guideline on Capacity Allocation and Congestion Management,
- Commission Regulation (EU) 2016/1719 of 26 September 2016 establishing a guideline on forward capacity allocation, and
- Commission Regulation (EU) 2017/2195 of 23 November 2017 establishing a guideline on electricity balancing,

and *System Operation Codes*:

- Commission Regulation (EU) 2017/1485 of 2 August 2017 establishing a guideline on electricity transmission system operation, and
- Commission Regulation (EU) 2017/2196 of 24 November 2017 establishing a network code on electricity emergency and restoration.

The Methodology is coherent with the solutions provided in the Connection Rules and the content of the documents which are adopted by the Independent System Operator in Bosnia and Herzegovina (NOS BIH) and approved by SERC: *Grid Code*, *Market Rules* and *Procedures for ancillary services* (please see Section 3.2).

Pursuant to the Methodology, SERC sets the coefficients and price caps for ancillary services. During the implementation of the market-based model of the BIH power system balancing, some tendencies had been noticed, so there was a need to update some coefficients and price caps for ancillary services in line with the conduct of participants and trends present on the market. SERC passed the *Decision on determination of coefficients and price caps for ancillary services* on 17 October 2025, which was amended on 11 December 2025.

Rules of Ancillary and System Services and Balancing of the BIH Power System

Within its activities the State Electricity Regulatory Commission continuously monitors and supports the process of electricity market development in Bosnia and Herzegovina. Safe and reliable operation of the power system with a functional method of providing ancillary services is the main prerequisite for further market development and high-quality electricity supply of customers. An efficient balancing market has to be based on transparent relationships between all participants in the electricity market.

In cooperation with the Independent System Operator in BIH and other electric power companies, SERC established a market-based method of providing ancillary services and balancing of the power system of BIH using the fundamental solutions defined in March 2014 by establishing *A Concept of Ancillary Services for the balancing of the power system of Bosnia and Herzegovina*.

A number of activities of SERC and NOS BIH, which were described in detail in the previous Reports on Activities of the Regulatory Commission, resulted in a set of rules and decisions whereby on 1 January 2016 the market principles had been introduced into the formerly fully regulated method of providing ancillary services and the BIH power system balancing. In this manner, the functionality of open wholesale and retail electricity markets in Bosnia and Herzegovina was enhanced (please see Section 3.7).

The electricity balancing market in Bosnia and Herzegovina operated successfully since then and it sets an example of a successful model in South East Europe. Notwithstanding this, SERC continuously analyses the balancing market and the development of the European Union's energy *acquis* which becomes obligatory for BIH as well under the Energy Community mechanisms, coordinating its activities with the NOS BIH, which acts in accordance with the activities of the European Network of Transmission System Operators for Electricity (ENTSO-E) when developing its documents.

In this context, in 2025 the *Tariff Pricing Methodology for services of electricity transmission, operation of an independent system operator and ancillary services* was updated, *Market Rules and Procedure for Ancillary Service* were approved (please see Section 3.2), and a number of accompanying decisions were adopted.

With the continuation of the successful balancing market development, the offer of services increased and all ancillary services for 2026, except the automatic frequency restoration reserve capacity in the off-peak period, had already been procured through annual bids organised by the NOS BIH in December 2025.

Frequency containment reserve (FCR) was purchased for all hours in 2026 in the required amount of 15 MW/h, with the average price



of 3.66 EUR/MW/h, which is a 5% decrease compared with the previous year.

The capacity for automatic frequency restoration reserve (aFRR) was procured at prices which were slightly lower than the prices reached at the previous annual market-based procurement of this service. For the off-peak period (00-06 h), the achieved price was 21.92 EUR/MW/h (21.96 EUR/MW/h in 2025) and is very close to the price cap of 21.99 EUR/MW/h, while for the peak period (06-24 h) the average price amounted to 20.98 EUR/MW/h (21.03 EUR/MW/h in 2025). The aFRR in the peak period was procured for all hours of the year in the required quantities. However, during the annual procurement, the required quantities of aFRR in the off-peak period were procured only for the months of March, April and May, so the missing quantities (14.6% of the required annual volume is missing) will be the subject of monthly procurements during 2026.

Both upward and downward capacity for manual frequency restoration reserve (mFRR) was procured at the price which is lower compared with the previous year. The average price for upward reserve decreased by 4.8% (from 2.79 EUR/MW/h to 2.66 EUR/MW/h) and 17.3% for the downward reserve (from 0.53 EUR/MW/h to 0.44 EUR/MW/h). The upward mFRR was procured in the required volume of 196 MW/h for all months. The downward mFRR was also procured for the entire annual period in the required physical volume of 75 MW/h.

The procurement of electricity for covering of losses in the transmission system in 2026 was planned in an amount of 334 GWh. The approximate value of the procurement was set in accordance with the provisions of the *Tariff Pricing Methodology for services of electricity transmission, operation of an independent system operator and ancillary services* and the *Decision on determination of coefficients and price caps for ancillary services*, that is, by using the prices of futures of the European Energy Exchange – *EEX-PXE Hungarian Power Futures* increased by 25%, thus reaching the amount of 134.21 EUR/MW/h. In this public bid, in which four bidders participated, all required quantities were procured. An average price of 104.24 EUR/MW/h was reached, which means that the planned cost of procurement of electricity for covering of losses in the transmission system amounts to EUR 35,328,114.

Wholesale Market Integrity and Transparency

Electricity produced by power plants is often bought and sold several times on the wholesale market before delivery to the end customer. These transactions in electricity normally take place in large quantities and include electricity producers, traders, suppliers, large customers and even investment banks. Gas is traded in a similar manner. In Europe, several hundreds of companies are included in wholesale trading in electricity and gas conducting tens of thousands of transactions on the market on a daily basis.

Wholesale prices are very sensitive to the availability of production and transmission because energy has to be generated when needed. Prices may be affected by spreading false information on availability or reduced generation.

Given that large quantities of energy are traded across borders, traditionally it is difficult to discover possible price manipulations of this kind as national regulators did not have access to cross-border data. As a response to these facts, *Regulation (EU) No 1227/2011 of the European Parliament and of the Council of 25 October 2011 on wholesale energy market integrity and transparency* (REMIT) was adopted in the European Union. This Regulation introduces a common European framework on wholesale markets for:

- Definition of market abuse with regard to market manipulation, attempts to manipulate the market and insider trading,
- Introduction of the explicit prohibition of market abuse,
- Establishment of a new framework for the registration of market participants and wholesale market monitoring with the aim of detecting and preventing market manipulation and insider trading, and
- Definitions of prohibitions and the application of penalties at national level if market abuse is detected.

REMIT is applied to all market participants whose activities affect wholesale energy markets, that is, all natural or legal persons (including transmission system operators) carrying out or conducting transactions on one or several wholesale energy markets. All market participants with the seat in any EU country as well as those with the seat outside the EU if trading or placing orders on one or several EU markets are subject to this regulation.

The Ministerial Council Decision of 29 November 2018 expanded the Energy Community acquis to include *Regulation (EU) on wholesale energy market integrity and transparency* with required adaptations to the Energy Community legal framework and defining the obligation to implement it by 29 May 2020.

With regard to the obligations under REMIT specified for national regulatory authorities, it should be pointed out that pursuant to Article 4.2 point k) of the *Law on Transmission of Electric Power, Regulator and System Operator of Bosnia and Herzegovina*, SERC competences include creation and maintenance of competitive markets, and prevention and punishment of any predatory or anti-competitive conduct. Starting from the obligations of national regulatory authorities defined in this Regulation, and, on the basis of the aforementioned SERC competences, in 2020 SERC carried out a number of activities on transposition and implementation of REMIT in the electricity sector. In this context, SERC adopted *Decision on transposition of the Regulation on wholesale energy market integrity and transparency*, *Rules on wholesale electricity market integrity and transparency* and *Decision on the Register of*

Regulation (EU) 2024/1106 of the European Parliament and of the Council of 11 April 2024 amending Regulations (EU) No 1227/2011 and (EU) 2019/942 as regards improving the Union's protection against market manipulation on the wholesale energy market entered into force in the European Union on 7 May 2024. The revised REMIT introduces new measures to better protect the EU citizens and businesses from energy market abuse.

Adaptation and transposition of the revised REMIT into the Energy Community acquis is expected by the end of 2026.

participants in the wholesale electricity market with the corresponding forms which are available on the SERC website.

In the area of REMIT implementation, special attention is paid to training of representatives of all relevant institutions and market players.

SERC was the first Energy Community regulator that successfully completed its activities on transposition and implementation of the adapted REMIT Regulation in the electricity sector by the establishment of the *Register of participants in the wholesale electricity market*. In 2025, this register was updated on a regular basis, and at the end of the year, it included all required data on 29 participants in the wholesale electricity market in Bosnia and Herzegovina.

An additional step forward in the development of market transparency was made by the implementation of *Commission Regulation (EU) No 543/2013 of 14 June 2013 on submission and publication of data in electricity markets and amending Annex I to Regulation (EC) No 714/2009 of the European Parliament and of the Council* (Transparency Regulation). SERC monitored the activities of NOS BIH in this area with particular attention.

NOS BIH collects and processes the basic electricity and market data of the BIH control area for their submission to the European Network of Transmission System Operators (ENTSO-E), which collects and publishes data and information on electricity generation, transportation and consumption for the pan-European market. All data are published on the *ENTSO-E Transparency Platform* pursuant to the obligations under Commission Regulation (EU) No 543/2013.

A high level of compliance with the requirements of this regulation has been reached. However, further digitalisation of business processes and the development of appropriate software solutions still remain to be done in the forthcoming period. Furthermore, it is necessary to establish certain procedures pertaining to weekly and monthly load forecast and re-dispatching to mitigate physical congestion, and, subsequently, publish generated data.

Cybersecurity

The security of supply is one of the key tasks of regulatory authorities in the electricity sector and a must when developing, adopting and implementing regulatory rules and regulations. There is a causal link between cybersecurity with the security of supply, and any cyber threat or risk is an important influential factor for the security of supply. It is of paramount importance for the reliable system operation and the protection of data in the electricity sector to acknowledge the need for proper measures for prevention, detection and response to all security challenges in the cyberspace in a timely manner. Lack of a strategic framework and systemic

rules regulating this issue does not relieve the regulatory authorities of the obligation to work on the protection of the electricity infrastructure and, consequently, the security of supply, by adopting their rules and taking appropriate measures.

In the previous period, the State Electricity Regulatory Commission contributed significantly to the preparation of several documents in this field, including *Bosnia and Herzegovina's Cybersecurity Capacity Review* and *Guidelines for a Strategic Cybersecurity Framework in Bosnia and Herzegovina*.

Since 2019 SERC actively participated in various regional projects and activities of several cybersecurity working groups and supported the work of the Computer Emergency Response Team for the institutions of BIH (CERT). The participation in these activities and several workshops dealing with various cybersecurity aspects created the preconditions for SERC to prepare *Guidelines for a Strategic Framework on Cybersecurity in Bosnia and Herzegovina Electricity Sector from Regulatory Perspective*

The State Electricity Regulatory Commission paid particular attention to the treatment of cybersecurity investments, and gave a significant contribution to the development of a *Draft roadmap for security of network and information systems in the BIH energy sector*. This document identifies general steps for the improvement of cybersecurity in the sector and provides guidelines for transposition and implementation of the relevant European Union directives (Directive NIS 1: *Directive (EU) 2016/1148 of the European Parliament and of the Council of 6 July 2016 concerning measures for a high common level of security of network and information systems across the Union*, and Directive NIS 2: *Directive (EU) 2022/2555 of the European Parliament and of the Council of 14 December 2022 on measures for a high common level of cybersecurity across the Union, amending Regulation (EU) No 910/2014 and Directive (EU) 2018/1972, and repealing Directive (EU) 2016/1148*).

In the past period *Cyber Incidence Coordination Protocol* was prepared which includes practical and detailed instructions on how to respond to such incidents as well as guidelines for communication with other commissions and stakeholders in the energy sector.

The State Electricity Regulatory Commission followed up the activities of the institutions of the European Union and the European Network of Transmission System Operators (ENTSO-E) which resulted in the adoption of *Commission Delegated Regulation (EU) 2024/1366 of 11 March 2024 supplementing Regulation (EU) 2019/943 of the European Parliament and of the Council by establishing a network code on sector-specific rules for cybersecurity aspects of cross-border electricity flows*. This document, whose adaptation and transposition into the Energy Community *acquis* is expected by the end of 2026, includes the rules for cybersecurity risk assessment, common minimum

cybersecurity requirements, cybersecurity certification of products and services, monitoring, reporting and crises management with the clear definition of roles and responsibilities of various stakeholders for each activity.

Taking into consideration a complex structure of the electricity sector and a specific regulatory framework in Bosnia and Herzegovina, it is found necessary to have coordinated action of the State and Entity Regulatory Commissions to establish an efficient regulatory approach to the field of cybersecurity. The goal is to protect information and communication systems of the entities in the BIH power sector and ensure cybersecurity of the regulatory authorities.

3.2 Documents Approved by SERC

Grid Code

The *Grid Code* is one of the key documents for functioning of the power system and electricity market in Bosnia and Herzegovina. It regulates the method of planning and developing the transmission system, connection requirements (procedures, contracts, criteria), the method of operational planning (demand forecast, network constraints management) and operational activities (dispatching, procedures, communications), measures in unexpected situations (demand management, operational restoration of the system after total or partial breakdown), metering code in the power system and other necessary technical measures for quality and reliable transmission system operation.

The purpose of the Grid Code is to define elements relevant for secure and reliable functioning of the BIH power system, enable development, maintenance and operation of the transmission network in compliance with the applicable rules and good European practice.

In the previous period, the need for updating the Grid Code was recognised, particularly in light of the interest and need for investments in renewable sources, accompanied by problems of management of the electric power system and balancing market of Bosnia and Herzegovina. The solution to part of these problems is recognised in the connection of electricity storage facilities, which would facilitate the management of the BIH system and enable the elimination of congestion that could potentially arise as a result of simultaneous generation of solar power plants during the midday hours.

The Grid Code, which was prepared by the Independent System Operator in Bosnia and Herzegovina in 2025, with comments from market participants obtained through the relevant Technical Committee, was submitted to SERC for approval on 23 April 2025.

SERC adopted the *Decision on approval and application of the Grid Code* on 12 May 2025.

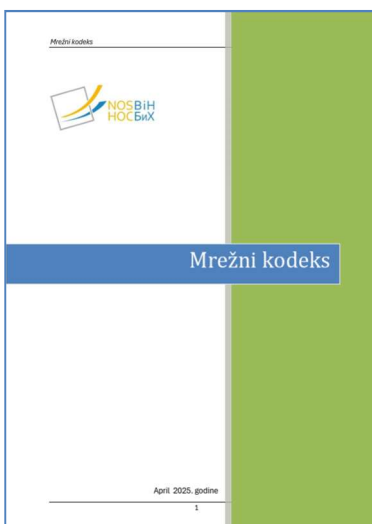

Market Rules

The *Market Rules* regulate relationships between NOS BIH and licensed participants on the electricity market. The purpose of the Rules is to create conditions for safe operation of the BIH power system, including efficient procurement of ancillary services and provision of system service, balancing of the BIH system at the lowest possible costs, and efficient functioning and further development of the wholesale and retail electricity markets in BIH.

The Market Rules are an exceptionally demanding technical document which includes the basic concept of market design, normative and regulatory framework for market design, technical preconditions for market functioning and provides a number of procedures regulating technical and commercial relationships among market participants.

The first Market Rules were prepared and approved in 2006. From January 2016, when a market-based method for provision of ancillary services and balancing of the electric power system of Bosnia and Herzegovina was established, until 31 December 2021 the Market Rules approved in May 2015 were applied. The Market Rules approved by SERC on 13 October 2021 were effectively applied since 1 January 2022.

The Independent System Operator in Bosnia and Herzegovina submitted the updated Market Rules to the State Electricity Regulatory Commission at the beginning of November 2024. When approving documents adopted by the regulated entity, SERC also analyses the procedure for their adoption in order to comply with one of the fundamental principles and standards of the applicable legislation in the legal procedure – transparency in work, and to enable the constructive participation of all relevant entities in the creation of rules and contribution to a higher quality text. Considering the above, assuming that NOS BIH implemented the procedure for adopting the Market Rules in the manner prescribed by law and documented the actions taken, SERC welcomed the activity on updating the Market Rules and requested information on the procedure carried out. The requested information was submitted in the middle of March 2025. NOS BIH submitted the new text of the Market Rules to SERC for approval on 23 April 2025. SERC adopted the *Decision on approval and application of the Market Rules* on 11 June 2025.

While preparing the Market Rules NOS BIH, as an ENSTO-E member, acted in accordance with activities of this organisation with regard to the operational activities in the synchronous area Continental Europe (please see Section 3.1).

NOS BIH is obligated to prepare the supporting acts related to the Market Rules and necessary software tools. In this context, of particular importance is a *Decision on temporary model which enables non-discriminatory and free access to the single electricity*

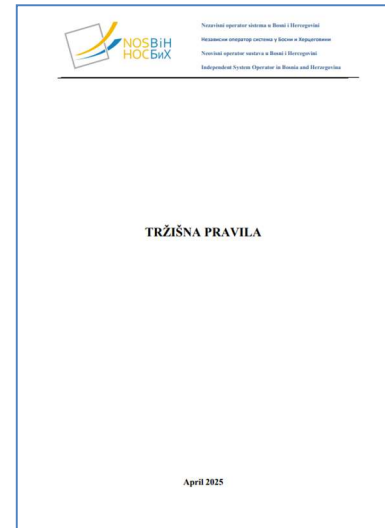



market in BIH by power plants connected to the distribution network, which was passed by NOS BIH on 11 April 2022. An integral part of this decision is the *Instruction for the implementation of the temporary model for 'virtual power plants' access to BIH electricity market*, which was updated several times (on 17 October 2022, 28 December 2022, 30 November 2023 and on 8 December 2025).

SERC representatives actively participated in the complex process of establishing the 'virtual power plant' concept. This temporary model was formed within the activities in which jointly participated all relevant stakeholders involved in operation of the various segments of the electricity market in Bosnia and Herzegovina – wholesale, retail and balancing market. Therefore, the participants in the establishment of the mentioned model were the three regulatory commissions in Bosnia and Herzegovina (SERC, FERK and RERS), NOS BIH, small producers, electricity suppliers and distribution system operators, i.e., electric power utilities. All these entities were actively involved in the creation of the model through their representatives in meetings of the working group established for this purpose.

The model of 'virtual power plants' access to the electricity market was established not only for its importance for the promotion of renewable electricity generation, improvement of services on the wholesale and local distribution market, optimisation of renewable energy generation with the electric power system needs, but also for the right of generators to free access to the electricity market established by law. Furthermore, the market-oriented concept of purchasing renewable electricity is gradually accepted instead of the former concept based on support schemes and guaranteed purchase, which is losing its importance due to a decrease in prices of generation technologies, resulting in higher competition of renewables compared with sources using fossil fuels.

Since 16 May 2022, when the first 'virtual power plant' occurred in the electric power system with only several megawatts of aggregated generation capacities, their number increased significantly. In December 2025, total installed capacity of all generation facilities with access to the BIH electricity market through six 'virtual power plants' amounted to 401.56 MW (where photovoltaic plants, small hydropower plants, biomass and biogas power plants, and small industrial power plants account for 278.11 MW, 109.99 MW, 2.46 MW and 11.00 MW respectively).

Procedures for Ancillary Services

For all its obligations specified in the *Tariff Pricing Methodology for services of electricity transmission, operation of an independent system operator and ancillary services* (please see Section 3.1), the Independent System Operator in Bosnia and Herzegovina develops procedures in a transparent manner in order to ensure

unhindered and timely performance of the activities under its competence. In this context, the *Procedures for ancillary services* are of particular importance. This document correlates both with the Grid Code and Market Rules. It specifies particular activities and their sequence as well as the rights and liabilities of the parties involved in the process of procurement, activation and settlement of ancillary services for the balancing of the electric power system of Bosnia and Herzegovina, covering of losses in the transmission system, elimination of unintentional deviations of the BIH load frequency control block and voltage and reactive power control.

NOS BIH submitted the updated Procedures for ancillary services on 13 October 2025. The State Electricity Regulatory Commission adopted the decision on approval of this document on 17 October 2025.

Indicative Generation Development Plan

An *Indicative Generation Development Plan* is developed for a ten-year period every year. The purpose of the plan is to inform the current and future users of the needs and existing projects for construction of new generation capacities. At the same time, this plan is used as one of the bases for the development of a *Long-Term Transmission Network Development Plan in Bosnia and Herzegovina*, which is also developed every year covering a ten-year period including the issue of new cross-border lines.

The main objective of the Indicative Generation Development Plan is to analyse the balance of capacity and energy in the transmission network for the following ten years. The development of this document is also in the function of fulfilling obligations towards the European Network of Transmission System Operators for Electricity (ENTSO-E).

The Independent System Operator in BIH, as all other system operators within ENTSO-E, is obligated to provide its contribution to the development of the *European Ten-Year Network Development Plan* (TYNDP), which is prepared on a biannual basis pursuant to Regulation (EU) 2019/943 on the internal market for electricity.⁴ In this context, NOS BIH is obligated to submit BIH power system development plans, which are based on consumption and generation, including new sources, and planned reinforcements of the internal transmission network and interconnections. These activities presume and imply full coordination at the regional level with the analysis of potential congestion in the internal network and cross-border lines.

⁴ Following public consultations, in the first quarter of 2025, the entire TYNDP 2024 package was submitted to the Agency for the Cooperation of Energy Regulators (ACER), which published its opinion on 26 May 2025. ENTSO-E was asked to consider the provided recommendations both to finalise this plan and to further improve its upcoming editions.



On 21 May 2025, NOS BIH submitted the *Indicative Generation Development Plan for the Period 2026 – 2035* to SERC for approval, which was preceded by a public hearing on the Draft document held on 29 April 2025. The State Electricity Regulatory Commission passed the *Decision on approval of the Indicative Generation Development Plan for the Period 2026 – 2035* on 11 June 2025.

SERC expects that the next Indicative Plan, whose development started in November 2025, would be updated with all the latest and relevant data and information available during its development.

Long-Term Transmission Network Development Plan

Pursuant to applicable legal provisions, a Long-Term Transmission Network Development Plan is developed on an annual basis and covers the forthcoming ten-year period. The Long-Term Plan should be submitted to SERC for approval by the end of October. The relevance of the Long-Term Plan is reflected in the fact that based on this plan Elektroprenos Bosne i Hercegovine prepares its annual investment plan and submits it to SERC for approval by the end of November for the following year. The development of the Long-Term Plan also ensures that obligations towards the European Network of Transmission System Operators for Electricity (ENTSO-E) concerning contributions to the development of the European Ten-Year Network Development Plan are met in a more suitable manner.

The Long-Term Transmission Network Development Plan should define the required reinforcements of the existing transmission network facilities and construction of the new ones to ensure timely commencement of activities with regard to designing, constructing and putting into operation of infrastructure necessary for the continuous supply and system stability. The transmission network planned in this manner provides the same conditions for the users already connected and those to be connected to the transmission network. It implies uniform conditions related to the condition of the transmission network in terms of lifespan and refurbishment of equipment, construction of new facilities and operational readiness of facilities used for the transmission of electricity.

The pace of the electricity sector development imposes the need for the permanent analysis and annual update of the criteria for determining the investment structure through the long-term plan, in order to direct individual investments as foreseen by investment plans towards the identified priorities and implement them accordingly.

On 18 May 2021, the State Electricity Regulatory Commission passed the *Decision approving the Long-Term Transmission Network Development Plan for the Period 2021 – 2030*. On that occasion, Elektroprenos Bosne i Hercegovine was bound to determine all necessary parameters required for the realisation of

Rules for Allocation of Cross-Border Transmission Capacities

The Coordinated Auction Office in South East Europe (SEE CAO) with the seat in Podgorica was formally established on 27 March 2014, commencing its operational activities on 27 November 2014 when annual auctions on the borders of Bosnia and Herzegovina with Montenegro and Croatia were organised.

In 2025, SEE CAO continued to organise its activities in line with auction rules for capacity allocation as approved by separate decisions of competent national regulators in the region, including the State Electricity Regulatory Commission. These rules include:

- Harmonised Allocation Rules for long-term transmission rights pursuant to Article 51 of Regulation (EU) 2016/1719 establishing a guideline on forward capacity allocation as amended in 2022,
- Specific annex for the bidding zone borders serviced by the Coordinated Auction Office in South East Europe (CAO SEE) to the Harmonised Allocation Rules for long-term transmission rights as amended in 2022,
- Rules for explicit daily capacity allocation on the bidding zone borders serviced by SEE CAO as amended in 2022,
- Participation Agreement between the Coordinated Auction Office in South East Europe d.o.o., Podgorica (Allocation Platform) and the Registered Participant,
- Financial conditions for participation in procedures organised by the Allocation Platform pursuant to the Participation Agreement,
- SEE CAO Nomination Rules, and
- SEE CAO Information System Rules.

As Serbia does not participate in activities of this office, there is still a need to regulate rules for allocation of cross-border capacities on the joint border between BIH and Serbia on an annual, monthly and daily basis. In this context, the following rules are implemented:

- *Rules for annual and monthly auctions for allocation of transmission capacities on the bidding zone borders between EMS AD Beograd (EMS) and the Independent System Operator in Bosnia and Herzegovina (ISO BIH), which were approved by SERC on 20 November 2024 at the request of NOS BIH, and*
- *Rules for daily auctions for allocation of transmission capacities on the bidding zone borders between EMS AD Beograd (EMS) and the Independent System Operator in Bosnia and Herzegovina (ISO BIH), which were approved by SERC on 17 November 2021 at the request of NOS BIH.*

As SEE CAO operations do not cover intraday allocation of cross-border transmission capacities, at the requests of NOS BIH the following documents were approved by the SERC decisions passed on 4 November 2020 and 17 November 2021:

- *Rules for intraday allocation of transmission capacities on the border between control areas of the Independent System Operator in Bosnia and Herzegovina (ISO BIH) and the Montenegrin Electric Transmission System AD (CGES),*
- *Rules for intraday allocation of transmission capacities on the bidding zones borders between the Independent System Operator in Bosnia and Herzegovina (ISO BIH) and EMS AD Beograd (EMS), and*
- *Rules for intraday allocation of transmission capacities on the border between control areas / Croatian Transmission System Operator (HOPS) and the Independent System Operator in Bosnia and Herzegovina (ISO BIH).*

The allocation of transmission capacities on the border with Serbia through annual, monthly and daily auctions will be conducted by *Elektromreža Srbije* (EMS) also in 2026 while intraday auctions will be conducted by NOS BIH. Intraday auctions on the borders with Croatia and Montenegro will be conducted by HOPS and NOS BIH respectively.

Operational Agreement of the SHB Load Frequency Control Block

On 9 November 2021, SERC passed the *Decision on Approval for Conclusion of Operational Agreement of the SHB Load Frequency Control Block*, between the transmission system operators of Slovenia, Croatia and Bosnia and Herzegovina, the text of which was agreed by the Parties.

A Load Frequency Control Block (LFC block) is a part of a synchronous area consisting of one or more LFC areas, physically demarcated by points of measurement at interconnectors to other LFC blocks, operated by one or more system operators fulfilling the obligations of load-frequency control. The Agreement defines the work of three system operators (ELES – Slovenian Transmission System Operator, HOPS – Croatian Transmission System Operator and ISO BIH – Independent System Operator in Bosnia and Herzegovina), in the part pertaining to operation of the relevant LFC block.

The *Operational Agreement of the SHB Load Frequency Control Block* (LFC Block SHB), which is in compliance with Commission Regulation (EU) 2017/1485 establishing a guideline on electricity transmission system operation, was signed in January 2022. Throughout 2025 NOS BIH acted in accordance with the provisions of the Agreement, with publication of the required information.

Cross-Border Exchange of Energy for Manual Frequency Restoration Reserve

In 2017, NOS BIH initiated the activities with the neighbouring system operators on the establishment of a model enabling the cross-border exchange of energy for manual frequency restoration reserve (previously used term: tertiary control energy). After a virtual cross-border line was registered in this context, NOS BIH submitted to SERC for approval the *Contract on mutual delivery of cross-border tertiary control energy for the provision of system services from abroad for the electric power systems of Bosnia and Herzegovina and Serbia*. The State Electricity Regulatory Commission approved this contract on 11 October 2017. At the beginning of 2018, the *Contract on mutual delivery of cross-border tertiary control energy for the provision of system services from abroad for the electric power systems of Bosnia and Herzegovina and Montenegro* was prepared, which was approved by SERC on 13 March 2018.

The subject of these contracts is the provision of assistance in the form of mutual delivery of cross-border energy for manual frequency restoration reserve in order to enhance secure and reliable operation of the neighbouring power systems. In this manner, the cross-border exchange of one of the products on the balancing market is formalised.

A virtual transmission line registered in the SCADA systems of the two operators for simulation of exchange is used for calculation of transactions, which is in line with the *ENTSO-E Continental Europe Operation Handbook*. For energy exchange in physical terms, the remaining available cross-border capacity is used after the completion of intraday capacity allocation.

In 2025, SERC monitored the cross-border exchange of energy for manual frequency restoration reserve (mFRR). In accordance with the signed documents, NOS BIH delivered a total of 719 MWh of positive balancing energy (upward balancing energy), the value of which amounts to EUR 305,970, with 450 MWh being delivered to *Hrvatski operator prijenosnog sustava* (HOPS) the value of which amounts to EUR 204,772, 171 MWh to *Elektromreža Srbije* (EMS) the value of which amounts to EUR 69,514 and 98 MWh to *Crnogorski elektroprivredni sistem* (CGES) the value of which amounts to EUR 31,684.

In the same period, 19 MWh of negative balancing energy (downward balancing energy) at a negative price was delivered, which is registered as a revenue of NOS BIH, the value of which amounts to EUR 3,835. The partner in this transaction was *Sistemski operator prenosne mreže Slovenije* (ELES). An amount of 156 MWh of negative balancing energy was purchased from HOPS at a negative price the value of which amounts to EUR 17,986, which is registered as an expenditure of NOS BIH.

NOS BIH purchased positive balancing energy in the amount of 884 MWh the value of which amounts to EUR 349,858, with 587 MWh being purchased from EMS (EUR 117,934), 160 MWh from CGES (EUR 43,600) and 137 MWh from HOPS (EUR 188,324). With this, the value of imports amounting to EUR 58,039 was registered in the balance of cross-border exchange of balancing energy.

Cross-border exchange of electricity for manual frequency restoration reserve with HOPS and ELES was carried out in accordance with the *Operational Agreement of the SHB Load Frequency Control Block*.

3.3 Licensing and Preliminary Permit Issuance Proceedings

In 2025, SERC issued several licences, while at the time of creating this report, it was intensively working on the application for issuance of a licence for the international electricity trading activity filed by GEN-I d.o.o., Sarajevo.

Due to the expiration of the term of the previously issued licenses for the international electricity trading activity, the proceedings were conducted and five-year term licenses were renewed to the following entities:

- Petrol BH Oil Company d.o.o., Sarajevo (February 2025),
- Disam BH d.o.o., Sarajevo (February 2025),
- ENNA Next BH d.o.o., Sarajevo (October 2025),
- HEP Energija d.o.o., Mostar (October 2025),
- Danske Commodities BH d.o.o., Sarajevo (November 2025) and
- Interenergo d.o.o., Sarajevo (November 2025).

A temporary licenses for the international electricity trading activity with two-year term was granted to the legal person

- Renewable Energy Solutions BH d.o.o., Banja Luka (September 2025).

All the licences for the international electricity trading activity are used pursuant to the *Standard licence conditions for performance of the international electricity trading activity*. By the adoption of these conditions as a standard set of rules on the rights and obligations of the licensee known beforehand (the acceptance of which is confirmed by submitting a written statement to that effect already with the licence application), SERC further simplified and expedited the procedure for granting this type of licence, which is most common in practice. This also considerably reduced the number of documents which circulated so far both within SERC and in communication with the applicant and interested third parties due to formal and procedural reasons. The Standard Conditions

stipulate that the licensee, during the term of the license, is obliged to permanently fulfil the general and specific criteria established by the Licensing Rule, on the basis of which the license was issued, and to submit the relevant evidence thereof to SERC.

After the notification of the change of seat and address, founder, equity as well as the persons authorised to represent the legal person, in September 2025, after the completion of the relevant procedure, the Decision on amendment to the Decision on issuance of licence for the international electricity trading activity to Green Energy Trading – Trgovina zelenom energijom d.o.o., Čitluk, was adopted.

In January 2025, due to the change of the company's name, the Decision on the continued use of temporary licence for the international electricity trading activity for Koksara d.o.o., Lukavac (previous name: Global Ispat koksna industrija d.o.o., Lukavac) was adopted.

At the request of the licensee, in May 2025, the Decision on suspension of temporary licence for performance of international electricity trading activity until 12 May 2026 for Koksara d.o.o., Lukavac, was adopted. Taking into consideration that in November 2025 a bankruptcy proceeding was opened over the assets of Koksara, which was beyond any doubt a serious indication that the holder of the temporary licence had ceased to fulfil the criterion of financial capacity, in December 2025 SERC initiated the procedure for revocation of the temporary licence issued to this legal person. This procedure is conducted in the same manner as the procedure for the issuance of a licence, which implies informing the public of the planned activities in the procedure and holding a general public hearing with a view to collecting comments of the public and interested parties.

On 25 December 2025, SERC was informed that the legal person Interenergo d.o.o., Sarajevo continued its business activity under the name Kelag International d.o.o., Sarajevo, so, after the analysis of the submitted data, SERC will consider the adoption of a decision on the continued use of the previously issued licence for the international trading activity under the company's new name.

On 31 December 2025, the following 23 legal persons were registered for the international electricity trading activity in the Register of valid licences: Interenergo d.o.o., Sarajevo; GEN-I d.o.o., Sarajevo; Alpiq Energija BH d.o.o., Sarajevo; Elektrane Stanari d.o.o., Stanari; HSE BH Energetsko preduzeće d.o.o., Sarajevo; JP Elektroprivreda Hrvatske zajednice Herceg Bosne d.d., Mostar; JP Elektroprivreda Bosne i Hercegovine d.d., Sarajevo; MH Elektroprivreda Republike Srpske – Parent Company, a.d., Trebinje; Energy Financing Team d.o.o., Bileća; Winter Wind d.o.o., Tomislavgrad; Hifa-Oil d.o.o., Tešanj; Wasserkraft d.o.o., Banja Luka; Lager d.o.o., Posušje; Green Energy Trading – Trgovina zelenom energijom d.o.o., Čitluk;

Axpo BH d.o.o., Mostar; Energy Financing Team SE Bileća d.o.o., Bileća; MET Energy BH d.o.o., Banja Luka; Petrol BH Oil Company d.o.o., Sarajevo; Disam BH d.o.o., Sarajevo; Renewable Energy Solutions BH d.o.o., Banja Luka; ENNA Next BH d.o.o., Sarajevo; HEP Energija d.o.o., Mostar and Danske Commodities BH d.o.o., Sarajevo.

The Independent System Operator in Bosnia and Herzegovina Sarajevo and Elektroprenos Bosne i Hercegovine a.d. Banja Luka are holders of the licence for performance of the activity of an independent system operator and the licence for the electricity transmission activity respectively. JP Komunalno Brčko d.o.o., Brčko in addition to the licence for the electricity trading and supply activity in territory of BIH holds the licence for the electricity distribution activity in the Brčko District of BIH.

Every year, including this one, comparing the previous year's status Elektroprenos Bosne i Hercegovine updated and reported changes in overviews of the facilities used by the Company for performance of the electricity transmission activity as well as overviews of the transmission lines which are not owned by the Transmission Company and are not in the function of electricity transmission in BIH, on which SERC reached relevant conclusions in March 2025.

At the end of April 2025, a *Conclusion on update of annexes to the Licence Conditions for the electricity distribution activity* was adopted, that is, overviews of facilities used for this activity in the Brčko District of BIH.

In October 2025, the procedures for issuance of preliminary permits for construction of generation facilities in the area of the Brčko District of BIH were completed for:

- Ekoenergija d.o.o., Brčko (PVPP Brezovo Polje),
- SE-Solar Energy d.o.o., Zavidovići (PVPP Ivakićke),
- Ekoenergija d.o.o., Brčko (PVPP Donji Rahić – Kladje) and
- Yavuz Company d.o.o., Srebrenik (PVPP Vitanovići).

3.4 Monitoring of Activities of Licensed Entities

The State Electricity Regulatory Commission continuously monitors operations of the licensed entities and their compliance with the licence conditions. Monitoring is performed through analysis of regular and special reports submitted by all licensed entities as well as by visits to the licensees. The licensees submit annual, semi-annual, monthly and daily reports on individual activities of a financial, technical and organisational nature. In addition, licensees' reports on contingency events in the system are available.

Visits of SERC experts to the regulated entities enable a direct inspection of their documents and activities, which is of great

relevance in particular when analysing the financial position of an entity from the aspect of application of approved tariffs.

In October 2025, the following regulated entities were visited:

- Independent System Operator in Bosnia and Herzegovina,
- Elektroprenos Bosne i Hercegovine, and
- JP Komunalno Brčko.



SERC pays special attention to the compliance of the Independent System Operator in Bosnia and Herzegovina with the obligations which were stated in detail in the *Licence Conditions for activities of an independent system operator*. Continuous regulatory monitoring indicate that the provisions of these conditions are complied with to a large extent. Naturally, the activities in cases of emergencies in the BIH electric power system, including outages of generation facilities, events resulting in zero-voltage of busbars and occurrences of high-voltage levels in the BIH electric power system were analysed in particular.

NOS BIH was invited to submit timely reports on the commissioning of new facilities and the permanent decommissioning of the existing facilities, in the manner as prescribed in the Conditions. This is particularly relevant due to the accelerated pace of construction and commissioning of facilities for the generation of electricity from renewable sources, as well as the expected decommissioning of generation facilities that use coal as their primary energy source.

It was pointed out to the ISO that, according to the rules pertaining to the *Register of participants in the wholesale electricity market in BIH* (REMIT Register), a market participant may not submit a schedule and cannot enter the daily schedule if it is not registered in this register maintained by SERC.

During regulatory monitoring it was concluded that NOS BIH updated several documents, including the Grid Code, Market Rules and the Procedures for ancillary service, which SERC approved by its decisions. Updating of these documents was conducted in light of the interest and need for investments in renewable sources and connection of electricity storage and hybrid facilities to the transmission network.

As part of regulatory monitoring, SERC pays particular attention to reviewing financial performance indicators of Elektroprenos BIH, of which SERC gives its opinion during decision-making process in the proceedings for setting of the tariffs for electricity transmission services (please see Section 3.6).



Under regulatory monitoring, the obligations of Elektroprenos BIH to develop and submit in a timely manner planning documents on an annual basis – long-term transmission network development plans for a ten-year period, and develop and adopt annual investment plans were pointed out in particular (please see Section 3.2).

The obligation of Elektroprenos BIH set under the law is to enable continuous electricity supply in accordance with the defined quality standards. The necessity to plan the transmission network development and the construction of new transmission lines in the areas where intense construction of renewable energy generation facilities is expected, was stressed in particular.

SERC has been pointing out for years that the voltage levels in the BIH power system are very often above the prescribed limits. This is one of the most serious problems in the transmission network in Bosnia and Herzegovina. In this context, a more active engagement of Elektroprenos BIH is necessary in the procurement and installation of compensation devices, i.e., shunt reactors. Elektroprenos BIH is requested by SERC to resolve this issue urgently and provide timely and complete pieces of information on all activities under this activity of utmost importance.

Elektroprenos BIH was invited again to establish a new approach to the classification of unplanned outages under its jurisdiction by adopting an appropriate rulebook. Namely, in addition to the aggregate indicators, which are monitored and at the level of the Company submitted to SERC in a regular manner, their differentiation to the level of operational areas, that is, field units, is necessary. This would identify less reliable facilities in an appropriate manner, which might direct investments to the necessary locations.

As part of regulatory monitoring, SERC pays particular attention to reviewing financial performance indicators of Elektroprenos BIH, of which SERC gives its opinion during decision-making process in the proceedings for setting of the tariffs for electricity transmission services (please see Section 3.6).

As part of regulatory monitoring of JP Komunalno Brčko, SERC recognised the recent development of legal framework on electricity in the Brčko District of BIH. SERC supports the regulated company which clearly supports the application and implementation of the adopted acts within its legal and other capacities. However, the *Law on Amendment to the Law on Renewable Energy Sources and Efficient Cogeneration of the Brčko District of Bosnia and Herzegovina*, which was adopted by the Assembly of the Brčko District of BIH on 15 October 2025, is not in compliance with the provisions of Article 4.2. of the *Law on Transmission of Electric Power, Regulator and System Operator of Bosnia and Herzegovina* which defines the jurisdiction of SERC regarding the Brčko District of BIH. SERC informed the Assembly of the Brčko District of BIH of this inconsistency and called upon it to include new amendments to the Law on Renewable Energy Sources and Efficient Cogeneration of the Brčko District of Bosnia and Herzegovina in its plans in 2026 as a priority, in order to remove the mentioned inconsistency.

SERC constantly pointed out the lack of regulation of mutual ownership relationships between the institutions of the Brčko District of BIH and JP Komunalno Brčko over the assets in the



function of electricity distribution and supply. The necessity of full unbundling of accounts for distribution and supply activities as well of these activities and other non-energy activities was repeatedly emphasised (water production and distribution, landscaping and maintenance of public areas and collection, transport and disposal of waste materials).

As part of regulatory monitoring, SERC pays particular attention to reviewing financial performance indicators of JP Komunalno Brčko, of which SERC gives its opinion during decision-making process in the proceedings for setting of the tariff rates for electricity distribution services and tariff rates for electricity supply within the universal service in the Brčko District of BIH (please see Section 3.6).

3.5 Technical Aspect of Transmission System Operation

The BIH electric power system operation in 2025 was stable and without any major problems. All system users were able to operate functionally in line with the defined quality standards. All planned or additionally requested maintenance works in the transmission network were fully completed.

The final report on the grid incident in South East Europe which occurred on 21 June 2024 (please see the SERC 2024 Annual Report) was published on 25 February 2025 by the relevant Expert Panel established by ENTSO-E. The report was prepared in accordance with the ENTSO-E *Incident Classification Scale* and (adapted) *Commission Regulation (EU) 2017/1485 establishing a guideline on electricity transmission system operation*. According to the published report, the regional system blackout was caused by the failure of two 400 kV transmission lines (TL Podgorica 2 – Ribarevine and TL Zemblak – Kardia) due to a short circuit caused by the shortening of the distance between the phase conductors and vegetation under the transmission lines. In 2025, two serious incidents occurred in the Continental Europe Synchronous Area.⁵

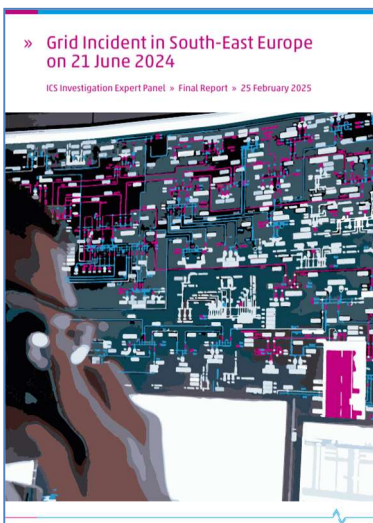

⁵ On 28 April 2025, at 12:33, the power systems of Spain and Portugal experienced a complete blackout that lasted 10 hours. A small area in France near the Spanish border also experienced a power outage of limited duration. This was the most serious incident that occurred in the European power system over 20 years.

On May 18, 2025, at 04:59, the power system of North Macedonia experienced a separation of the 400 kV and 110 kV voltage levels, which led to a loss of stability, power supply and a full blackout in the 110 kV transmission network, while the 400 kV transmission network remained in operation. On the same day, the Bulgarian control area entered an alert state for 8 hours due to high voltages in the western part of their system. The restoration of the system was completed by 07:47 on the same day.

In both cases, the remainder of the Continental Europe power system, including Bosnia and Herzegovina, did not experience any significant disturbance. On these occasions, ENTSO-E established two expert panels tasked to investigate the root causes of the incidents, develop a comprehensive study and publish a final report. The interim (factual) reports on the incidents on the Iberian Peninsula and in North Macedonia were published on 3 October 2025 and 10 November 2025 respectively.

The maximum hourly load of the power system in 2025 amounting to 2,209 MW was reported on 31 December 2025 at the 18th hour. This exceeded the previous historical maximum of 2,207 MW reported at the same hour and date in 2014. Maximum daily electricity consumption of 43,051 MWh was recorded on 30 December 2025. Minimum hourly load of 591 MW was reported on 14 May 2025 at the 14th hour, which is 6 MW less than the previous minimum hourly load which was reported at the 4th hour on 12 June 2023. Minimum daily electricity consumption of 18,703 MWh was recorded on 1 May 2025.

Maximum and minimum hourly loads in 2025 and over the past ten years are presented in Figures 1 and 2 respectively.

Unintended deviations from declared exchange schedules towards the neighbouring power systems in 2025 amounted to 110.75 GWh in total at hours when an electricity deficit was registered in the BIH control area and 45.10 GWh in total at hours when an electricity surplus was registered. Monthly deviations of the BIH electric power system in 2025 are presented in Figure 3.

Figure 1. Maximum and minimum hourly load in 2025 by month (MW)

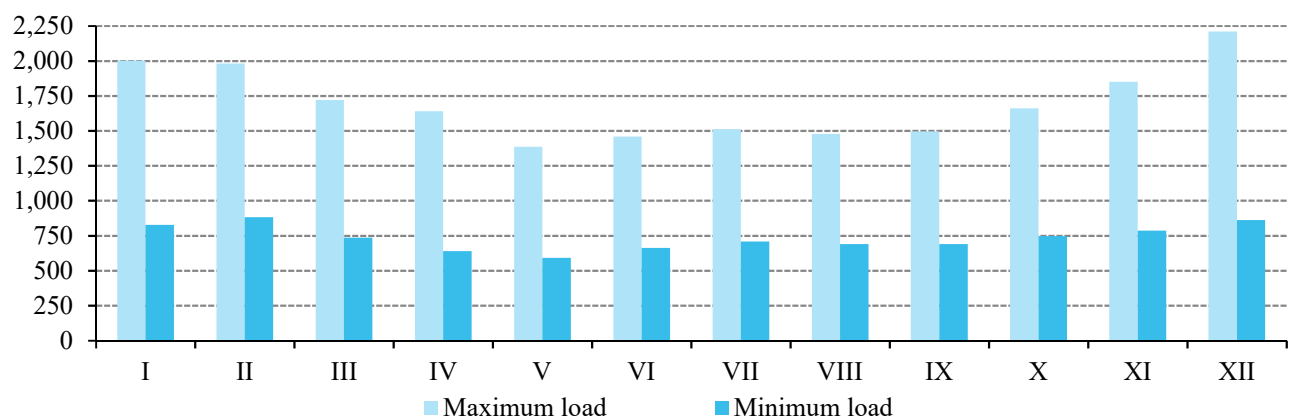

Figure 2. Maximum and minimum hourly load in the period 2016 – 2025 (MW)

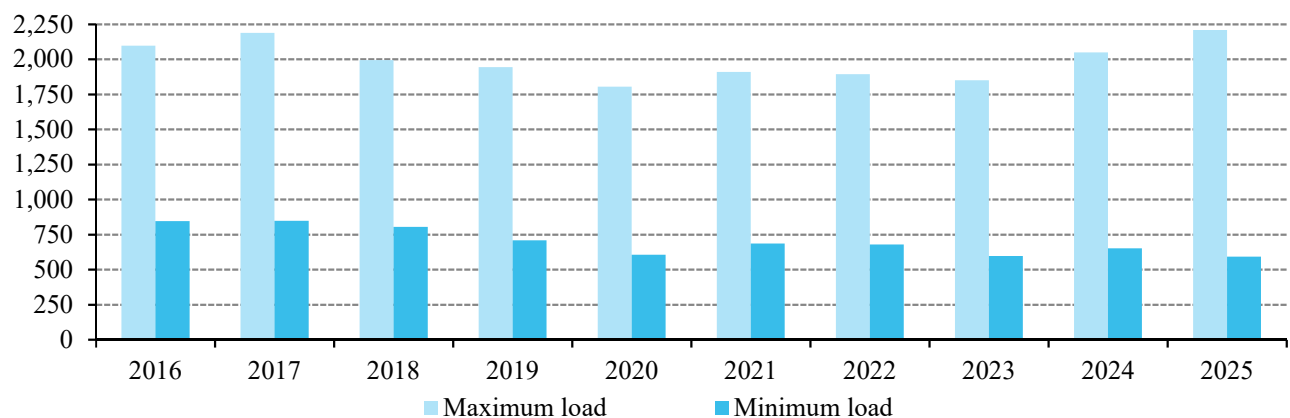

Figure 3. Monthly deviations of BIH power system in 2025 (GWh)

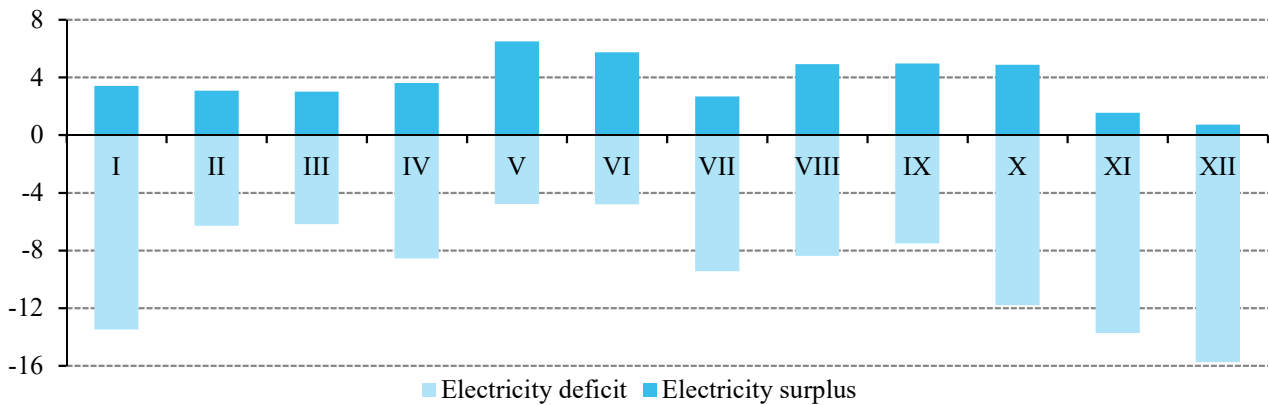
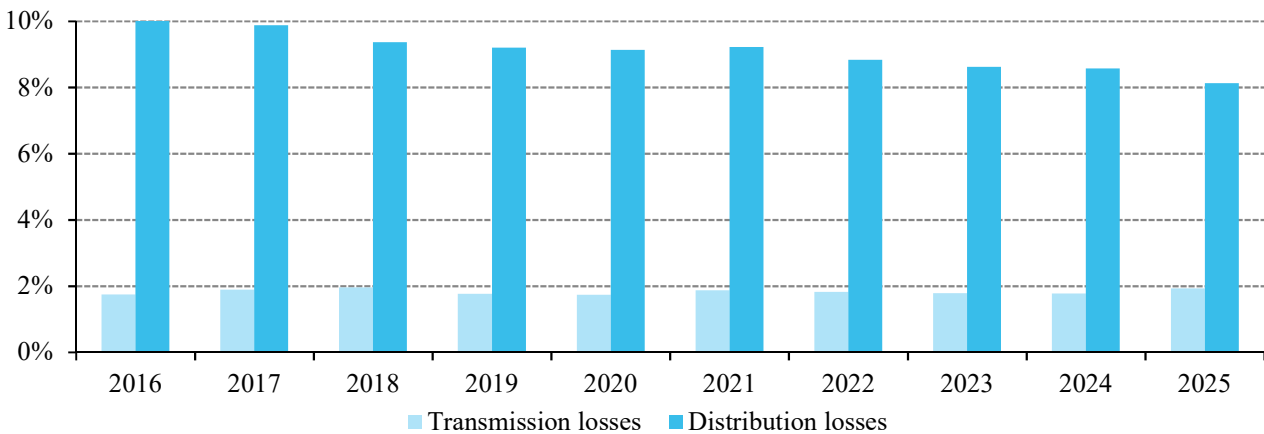

Figure 4. Transmission and distribution losses



In June 2025, a maximum hourly electricity deficit (downward deviation) was registered amounting to 172 MWh/h as well as a maximum surplus (upward deviation) amounting to 199 MWh/h.

Total electricity in the transmission network amounted to 18,126 GWh, which is 1.83% less than in 2024. Transmission losses amounted to 350 GWh, or 1.93% of total energy in the transmission system. In 2025, distribution losses amounted to 914.58 GWh or 8.13% in relation to total consumption by customers connected to the distribution network, which is the lowest level in the history of the BIH electric power sector. Percentage of transmission and distribution losses in the period 2016 – 2025 is presented in Figure 4.

Pumped-storage hydropower plant Čapljina withdrew 52 GWh from the transmission system, while total production of this power plant amounted to 173 GWh.

Data on energy not supplied (ENS) due to unplanned interruptions (ENS_{unpl}), as well as energy not supplied due to planned interruptions (ENS_{pl}) in the BIH power system over the past five years are provided in Table 1.

Table 1. Energy not supplied due to interruptions in the transmission network

	2021		2022		2023		2024		2025	
	MWh	min	MWh	min	MWh	min	MWh	min	MWh	min
ENS _{nep1}	678.07	14,788	664.03	9,086	1,063.92	12,407	5,792.13	42,941	529.28	6,578
ENS _{pl}	690.82	9,503	1,029.15	13,835	649.75	15,095	1,007.27	15,903	1,086.93	18,731
<i>Ukupno</i>	1,368.89	24,291	1,693.18	22,921	1,713.67	27,502	6,799.40	58,844	1,616.21	25,309

Table 2. Average interruption time in the transmission network by month (min)

Month	I	II	III	IV	V	VI	VII	VIII	IX	X	XI	XII
AIT ₂₀₂₁	0.4481	0.7509	3.9080	2.1174	3.9190	5.1968	4.4001	5.9464	4.9027	5.9328	4.5592	3.7586
AIT ₂₀₂₂	0.2022	0.2739	3.7850	0.6587	17.4503	3.6111	3.6504	3.5146	0.0283	7.2689	2.1352	2.9838
AIT ₂₀₂₃	0.0000	18.7327	3.0766	2.3987	0.9050	1.2518	5.4480	0.7141	2.0729	7.7161	0.1479	0.3243
AIT ₂₀₂₄	1.1069	4.0361	5.8034	6.3806	9.3486	118.5551	3.3927	2.6348	6.1038	3.6341	2.6440	117.3645
AIT ₂₀₂₅	0.7903	0.3898	3.7921	0.9533	9.8808	8.4055	0.1111	13.5516	8.6969	6.9755	8.0548	0.0909

Table 2 contains data on continuity of supply, that is, the average interruption time (AIT) in the high-voltage transmission network.

In 2025, several contracts on construction, reconstruction and rehabilitation of transmission facilities were completed, thus increasing the security of electricity supply for customers.

Several wind power plant and solar photovoltaic power plants were connected to the transmission network.

The new SS 110/30 kV Ivan Sedlo, which was built to connect the wind power plant of the same name with installed capacity of 25 MW, was commissioned on 13 February 2025. The substation was connected to the transmission network with the entry-exit system to the 110 kV transmission line traction power substation (TPSS) Konjic – Pazarić, thus forming two new transmission lines, TL 110 kV TPSS Konjic – Ivan Sedlo and TL 110 kV Ivan Sedlo – Pazarić. Electricity generation in the Ivan Sedlo wind power plant started on 27 February 2025.

At the 220/20 kV Hodovo substation, which was commissioned in 2024 and through which phases I and II of the Eco-Wat photovoltaic power plant were connected to the power transmission system in the same year, on 8 April 2025, phase III with installed capacity of 12 MW was also connected, bringing the total installed capacity of this power plant to 104.47 MW.

On 28 May 2025, electricity generation started at the photovoltaic power plant Brotnjo 1 and 2 with installed capacity of 9.98 MW, connected to the transmission network through the substation SS 110/20 kV Brotnjo, which is directly connected to the substation SS 110/x kV Čitluk 2.

The new substation SS 110/20 kV Polog was commissioned on 13 June 2025. It was built to connect the following photovoltaic power plants: Polog with installed capacity of 7.99 MW (owned by Pozitron d.o.o., Mostar), Plavo sunce 55, 56, 57, 58 and 59 with installed capacity of 20 MW (owned by ECCO Solar Energy d.o.o., Čitluk) and Plavo sunce 2, 3, 52, 53 and 54 with installed capacity of 20 MW (owned by MIM energija d.o.o., Čitluk). The substation was connected to the transmission network with the entry-exit system to the 110 kV transmission line Mostar 4 – Široki Brijeg, thus forming two new transmission lines, TL 110 kV Mostar 4 – Polog and TL 110 kV Polog – Široki Brijeg. Electricity is injected into the transmission system through this substation from 14 June 2025.

In a similar manner, on 16 December 2025 the substation 110/33 kV Oštrc was connected to the 110 kV transmission line Gornji Brišnik – Posušje with the entry/exist system, thus forming two new transmission lines, TL 110 kV Gornji Brišnik – Oštrc and TL 110 kV Oštrc – Posušje. This enabled the connection of the wind power plant Oštrc with installed capacity of 28.8 MW (6×4.8 MW) to the power transmission system. Electricity generation in this wind power plant started on 25 December 2025.

The automatic frequency restoration reserve (aFRR) services in 2025 were provided by JP Elektroprivreda Bosne i Hercegovine d.d., Sarajevo and MH Elektroprivreda Republike Srpske – Parent Company, a.d., Trebinje. During the year, the manual frequency restoration reserve (mFRR) was activated 341 times (227 times as upward mFRR, of which 57 times in September, and 114 times as downward mFRR, of which 21 times in August). However, the nominated mFRR volumes were often insufficient.

In 2025, 411 outages were registered in the transmission network at 400 kV, 220 kV and 110 kV voltage levels, of which, 97, 144 and 153 outages at 400 kV, 220 kV and 110 kV transmission lines respectively. Furthermore, 11 outages of 400/220 kV, 400 MVA transformers were registered, two outages of 400/110 kV, 300 MVA transformers and four outages of 220/110 kV, 150 MVA transformers.

In the previous year, 59 failures of thermal power blocks and nine outages of hydro generators were registered. Missing energy in the system was compensated through the manual frequency restoration reserve.

In 2025, in the BIH electric power system zero-voltage of busbars was registered 60 times, of which 44 times at 400 kV busbars lasting 227 hours and 13 minutes in total, one time at 220 kV busbars lasting 32 hours and 26 minutes and 15 times at 110 kV busbars lasting 8 hours and 27 minutes. Most of them took place in the period from May to August, when the highest number of atmospheric electricity charges was registered, which caused zero-voltage in most of the cases.

Similar to the previous years, in 2025 voltage levels in the power system often exceeded the values prescribed by the Grid Code, in particular in the 400 kV and 220 kV network. The highest voltage level in the 400 kV network was registered at SS Sarajevo 10 in April, when the measured voltage level reached 455.22 kV. The highest voltage level in the 220 kV network was measured in August, at SS Jajce 2 (262.47 kV). The highest voltage level in the 110 kV network of 124.04 kV was measured in June in the same substation.

The main reason for occurrence and duration of high voltage levels is under-loaded 400 kV transmission lines during low demand periods which generate large volumes of reactive power. The occurrence of high voltage levels is a regional problem and, consequently, solutions to this problem are also sought at regional level. With the aim of contributing to a long-term and quality solution to this problem, SERC continues to insist on conducting investment activities for the instalment of shunt reactors in the BIH power system, in addition to implementing all other measures to keep the voltage levels within the prescribed limits.

The quality of the power system operation is monitored by analysing the Transmission Company's data on technical aspects of the transmission system operation, which, in addition to the indices of continuity of customer supply ENS and AIT, are also presented by the SAIFI and SAIDI indices.

The SAIFI and SAIDI indices are obtained by monitoring the number and duration of interruptions in the Transmission Company's

Table 3. SAIFI and SAIDI for the transmission network

		2021	2022	2023	2024	2025
SAIFI	Planned interruptions	0.47	0.51	0.57	0.59	0.56
	Unplanned interruptions	0.74	0.75	0.86	1.97	0.52
	<i>Total</i>	1.21	1.26	1.43	2.56	1.08
SAIDI	Planned interruptions (min/customer)	51.78	61.69	66.69	71.60	77.93
	Unplanned interruptions (min/customer)	26.39	30.62	61.69	231.82	39.75
	<i>Total (min/customer)</i>	78.17	92.32	128.37	303.42	117.68

Table 4. SAIFI and SAIDI for the transmission network including outages of middle voltage feeders caused by interruptions in the distribution network

		2021	2022	2023	2024	2025
SAIFI	Planned interruptions	2.96	2.67	3.56	4.23	3.74
	Unplanned interruptions	4.47	3.94	4.92	5.40	3.36
	<i>Total</i>	7.43	6.61	8.48	9.63	7.11
SAIDI	Planned interruptions (min/customer)	205.69	316.50	287.72	329.83	500.23
	Unplanned interruptions (min/customer)	359.62	279.45	420.95	712.38	531.24
	<i>Total (min/customer)</i>	565.31	595.95	708.67	1,042.21	1,031.47

The SAIFI index (System Average Interruption Frequency Index) indicates the average number of interruptions per customer during a year.

The SAIDI index (System Average Interruption Duration Index) indicates the average interruption duration for each customer in minutes per year.

facilities resulting in supply interruptions for customers directly connected to the transmission network and/or zero-voltage in middle voltage feeders exceeding three minutes.

Tables 3 and 4 show the SAIFI and SAIDI indices for the past five years. Table 3 includes only interruptions caused by events in the network under the responsibility of Elektroprenos BIH, while Table 4 also includes interruptions in middle voltage feeders in the Transmission Company's substations caused by disturbances in the distribution network which are significantly less favourable, taking into consideration outspread connections and length of the distribution network and its tendency to various failures.

The basic data on the BIH electric power system and the map of the system are provided in Annexes A and B respectively.

3.6 Tariff Proceedings

Tariffs for Electricity Transmission Services

In 2025, Elektroprenos Bosne i Hercegovine did not file an application for modification of the electricity transmission tariffs. Within the continuous regulatory monitoring and monitoring of Elektroprenos BIH activities, SERC concluded that the revenues realised by the regulated company are sufficient to cover the actual costs.

The fact that the increase in the wholesale prices in the region resulted in an increase in revenues which Elektroprenos BIH realises through auctions for allocation of cross-border capacities was not neglected. Consequently, based only on the annual auctions for 2023 (which were held in December 2022), an amount of EUR 8,777,301 was collected. In 2023, the revenues based on the monthly auctions amounted to EUR 8,156,458 while the revenues based on the daily and intraday auctions amounted to EUR 816,974. The revenues based on the annual auctions for 2024, which were held in December 2023 amounted to EUR 7,482,958, while those from daily and intraday auctions amounted to EUR 2,139,916. The result of annual auctions for 2025, which were held in December 2024, amounted even to EUR 13,984,026.

In 2025 the revenues based on the monthly auctions amounted to EUR 9,871,793 while the revenues based on the daily and intraday auctions amounted to EUR 970,059. Based on the annual auctions for 2026 (held in December 2025), an amount of EUR 7,795,524.70 was collected. Until 2022, total revenue from auctions amounted between EUR 3 million and EUR 3.5 million annually (please see Section 3.7).

Therefore, the SERC Decision effective as of 1 May 2017 practically continues to apply. Consequently, the part of the transmission network charge pertaining to energy remains 0.30 euro cents/kWh while the part of the transmission network charge pertaining to capacity amounts to 0.753 EUR/kW (an average transmission network charge amounts to 0.45 euro cents/kWh).

The SERC rules enable Elektroprenos Bosne i Hercegovine to file a new application for approval of a tariff for electricity transmission services in line with its estimations based on the latest financial and energy values.

Tariff for Operation of an Independent System Operator; Tariffs for System and Ancillary Services

Pursuant to the legal obligation to submit for consideration the applications for revenues and expenditures in the following year as well as costs that the Company plans to include in its tariffs, the Independent System Operator in Bosnia and Herzegovina by its act of 24 October 2025 filed such an application, in which it presented and explained the planned revenues, expenditures and costs in 2026. NOS BIH revised this application by its communication of 15 November 2025.

The revenue requirement for 2026 amounting to EUR 7,811,030 was requested, the requested tariff for operation of an independent system operator paid for electricity injected into the transmission system amounted to 0.053 EUR/MWh (a 22.62% increase), while the tariff paid for electricity withdrawn from the transmission system amounted to 0.672 EUR/MWh (a 20.33% increase). The proposed tariff for system service amounted to 7.203 EUR/MWh, which is 194.15% more than the tariff for the system service determined in the previous tariff proceedings which were finalised on 26 December 2025.

A formal public hearing in these tariff proceedings, in which, in addition to the regulated company, three interveners actively participated, was held on 27 November 2025 in Tuzla. *The Presiding Officer's Report* was distributed to the participants in the proceedings for comments on 3 December 2025.

On the basis of the Presiding Officer's Report, comments received from the regulated company and the interveners, and following the analyses of the required costs and expenditures and all other available documents, the State Electricity Regulatory Commission passed the *Decision on tariff for operation of an independent system operator* and the *Decision on tariffs for system and ancillary services* on 23 December 2025, which are effective from 1 January 2026.

It is determined that the annual revenue requirement of NOS BIH in 2026 amounts to EUR 7,218,125. The Decision specifies that the tariff for operation of an independent system operator which is paid for energy injected into the transmission system amounts to 0.0486 EUR/MWh (a 13.10% increase), while the tariff for operation of an independent system operator which is paid for energy withdrawn from the transmission network amounts to 0.599 EUR/MWh (a 7.23% increase).

According to the *Decision on tariffs for system and ancillary services*, the financial scope of the system service in 2026 amounts

to EUR 48,002,328. When determining the tariff for system service, based on the available data, it was concluded that it was possible to reduce the tariff for system service. Taking into account the present facts and respecting the precautionary principle due to a high number of variables affecting the revenues and expenditures in the balancing mechanism, the Commission decided to keep the tariff for system service at the same level of 2.449 EUR/MWh, announcing that on a needs basis it would initiate its adjustment when deemed appropriate.

Tariffs for Customers in the Brčko District of BIH

The proceedings for setting of the tariff rates for electricity distribution services and electricity supply within the universal service in the Brčko District of BIH were initiated on 17 December 2024, following an application which was submitted by the regulated company on 16 December 2024.

The Public Utility Komunalno Brčko, as the public supplier in the area of the Brčko District of Bosnia and Herzegovina which purchases all electricity for the supply of its customers on the wholesale electricity market, requested an increase in the tariffs applicable since 1 March 2023, i.e., amendments to the decisions on tariffs which would enable the following:

- A 27.5% increase in the costs of distribution network charge for all customers,
- A 24% increase in an average price for supply within the universal service for households and a 16.6% increase for the category ‘other consumers,’ i.e., commercial customers connected to the 0.4 kV voltage level with annual consumption not exceeding 35,000 kWh,
- A profit amounting to 2% of electricity purchase costs for the supply within the universal service, and
- An increase in the charge per customer’s metering point.

The regulated company stated an increase in the electricity purchase price for 2025 amounting to 9.00 euro cents/kWh as the main reason for initiating the tariff proceedings, which is 21.4% more compared with the price contracted for 2023 and 2024.

A formal public hearing in these proceedings, in which there were no interveners, was held on 21 January 2025 in Brčko. The *Presiding Officer’s Report* was submitted to the applicant on 27 January 2025, who stated in its communication of 31 January that the tariff proceedings had been conducted in a proper manner and that the proposed tariffs reflected the costs of their business operations to the maximum extent possible.

On 11 February 2025, SERC passed the *Decision on tariffs for electricity distribution services in the Brčko District of Bosnia and Herzegovina* and the *Decision on tariffs for electricity supply within the universal service in the Brčko District of BIH*, which are effective from 1 March 2025.

An average tariff for electricity distribution increased by 21.5% amounting to 3.64 euro cents/kWh.

An average electricity price for the customers supplied within the universal service increased by 9%, amounting to 11.23 euro cents/kWh for households and 12.40 euro cents/kWh for other consumers, that is, commercial customers connected to 0.4 kV and whose annual consumption does not exceed 35,000 kWh.

In the decision-making process SERC took into account the measures of the Brčko District Government under which a part of electricity costs for vulnerable customers is subsidised, which includes over 37% of households.

On 27 November 2025, the Public Utility Company Komunalno Brčko submitted a new application for the initiation of the proceedings for determining tariff rates for electricity distribution services and tariff rates for the supply of electricity within the universal service in the Brčko District of Bosnia and Herzegovina, upon which on 4 December 2025 SERC adopted a Conclusion on initiating the proceedings.

In its application, Komunalno Brčko requested:

- Approval of the revenue requirement for the electricity distribution activity amounting to EUR 9,602,611 for 2026, with the adjustment of the valid tariff rates within the approved costs in such a way that the average network fee, including all voltage levels, remains at the existing value of 3.64 euro cents/kWh, and
- An 11.34% increase in an average price for supply within the universal service with a 10.85% increase for households and a 14.23% increase for the category of ‘other consumers.’

As the main reasons for the application for initiating the tariff proceedings an increase in the electricity purchase price for 2026 was stated as well as an increase in the distribution costs.

A formal public hearing in these proceedings, in which there were no interveners this time either, was held on 18 December 2025 in Brčko. The *Presiding Officer’s Report* was submitted to the applicant on 29 December 2025.

The adoption of the decisions on the tariffs for distribution services and the tariffs for electricity supply within the universal service in the District is planned for the middle of January 2026, thus enabling their application as of 1 February 2026.

3.7 Electricity Market

In Bosnia and Herzegovina, electricity generation amounting to 14,540 GWh was reached in 2025, which is 14 GWh, or 0.1%, less compared with the previous year.

For the second year in a row, the hydrological conditions were extremely unfavourable, so generation by hydropower plants connected to the transmission system decreased by 299 GWh, or 6.3%, amounting to 4,433 GWh.

In comparison to the previous year, generation by coal-fired thermal power plants decreased by 6.5% amounting to 7,934 GWh, which is the lowest level of generation since 2006. With this, their share in total generation fell to 54.6%. While the thermal power plant Stanari reported a 2.9% increase in generation, the other four thermal power plants generated less than in the previous year.

Generation by wind power plants connected to the transmission system amounted to 648 GWh, which is 256 GWh or 65.1% more than in 2024. The new wind power plant Ivan Sedlo in the Municipality of Hadžići with installed capacity of 25 MW and the wind power plant Oštrc in the Municipality of Posušje with installed capacity of 28.8 MW have been in trial operation since 27 February and 18 December 2025 respectively.

In 2025, several new solar photovoltaic power plants were connected to the transmission system and one of the existing ones was expanded, which brought the total installed capacity of solar power plants connected to the transmission system to 306 MW. Their total generation reached 474 GWh, which is an increase of 127%.

Electricity generation from renewable energy sources in power plants connected to the distribution system amounted to 1,042.43 GWh, which is 46.8% more than in 2024. This increase is the result of a significant increase in generation by solar (photovoltaic) power plants, which produced 681.68 GWh, or 75.8% more than in 2024. Small hydropower plants produced 350.79 GWh, which is 12.3% more than in the previous year.

Generation by the four existing biomass and biogas power plants amounted to 9.96 GWh (9.98 GWh in 2024). Industrial power plants produced 8.64 GWh in total, which is significantly less than 26.46 GWh produced in the previous year.

So, a dynamic increase in solar power plants' installed capacity and their generation, which reached a total of 1,156 GWh, was noticeable although certain share of capacity (according to estimations some 50 MW) and generated energy from these sources was not possible to register precisely due to the specific status of self-consumption. When the total generation of wind power plants is added to the generation of solar power plants, an amount of 1,804.28 GWh is reached, with the generation of these intermittent renewable sources totalling a significant 12.4% of electricity generation in Bosnia and Herzegovina.

Electricity generation from all renewable sources in Bosnia and Herzegovina amounted to 6,597.62 GWh, which represents 53.5% in relation to the total consumption of electricity, which is above

the average of the European Union member states, which amounted to 47.5% in 2024.

A breakdown of generation over the last ten years is provided in Figure 5 while a breakdown of consumption in BIH is provided in Figure 6.

Total electricity consumption amounted to 12,330 GWh, which is 199 GWh or 1.6% more compared with the previous year. Consumption by the customers connected to the transmission system (HV customers) decreased even by 24.4% amounting 650 GWh. This is a consequence of the absence of consumption by one of the largest customers of electricity in Bosnia and Herzegovina – Metalleghe Silicon d.o.o., Mrkonjić Grad, that is, the shutdown of production in its metallurgical factories in Jajce and Mrkonjić Grad.

On the other hand, consumption by customers connected to the distribution network recorded an increase, and amounted to 11,252 GWh, which is 349 GWh or 3.2% more than in the previous year. The largest increase this year was again registered in the category of households (4.9%), where electricity is increasingly used for heating and cooling of premises. The increase in

Figure 5. Breakdown of electricity generation in BIH over the last ten years (GWh)

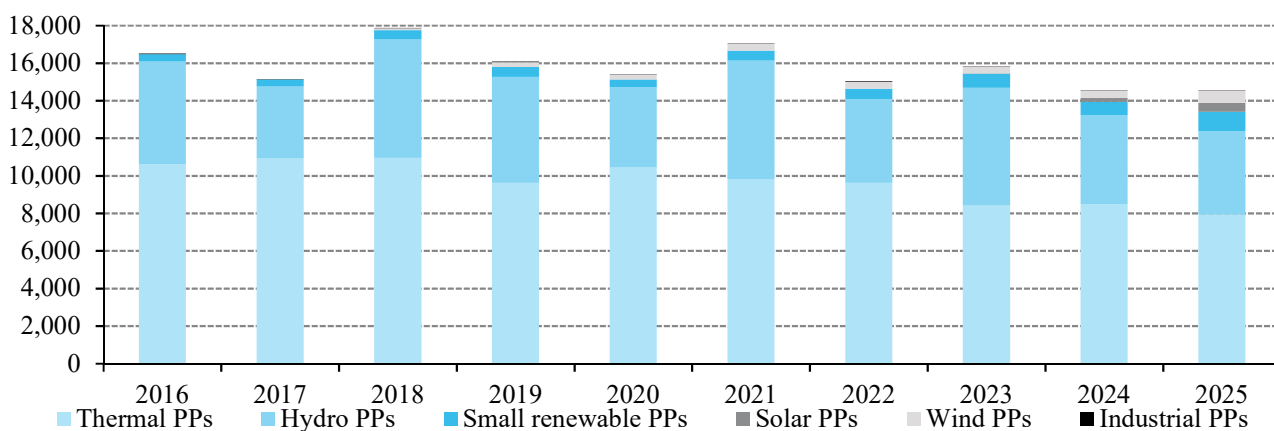
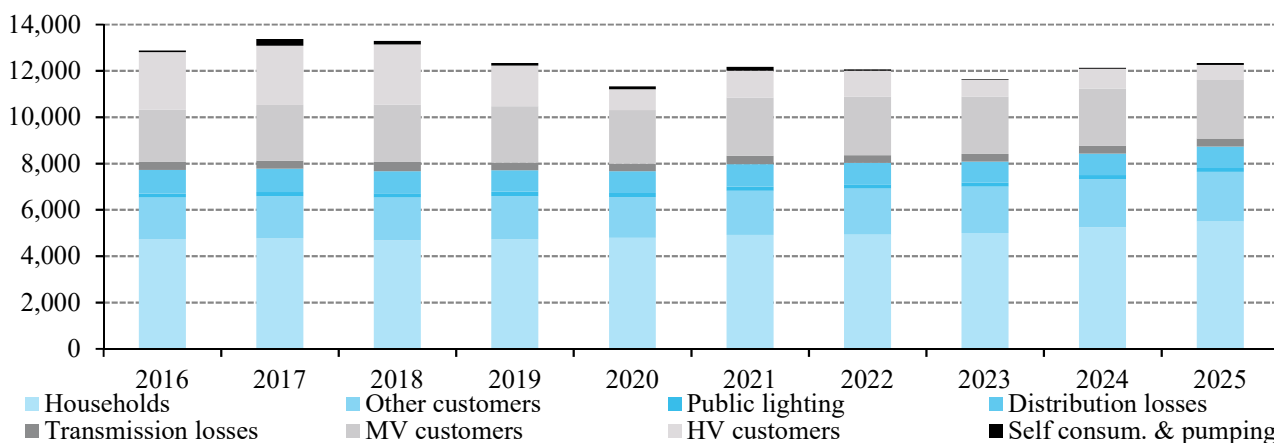

Figure 6. Breakdown of electricity consumption in BIH over the last ten years (GWh)



consumption was registered by the customers connected to 35 kV (4.4%) and 10 kV (1.9%) voltage levels and by 2.7% in the category of ‘other consumers’ (commercial customers connected to 0.4 kV). Public lighting consumption decreased by 2.5%. The consumption of households has been steadily increasing since 2018, and in 2025 it amounted to 5,501 GWh, which is 50.1% of total consumption by end users.

A total of 10,925 GWh of electricity was withdrawn from the transmission system, which is 34 GWh, or 0.3% less compared with 2024. In the development of the power system of Bosnia and Herzegovina so far, total electricity consumption and withdrawal of energy from the transmission system have shown the same tendency, that is, the same direction of change. This year represents a turning point because it is the first time that total electricity consumption has increased, while at the same time energy withdrawal from the transmission system has decreased, which indicates the growing volume of generation from the sources connected to the distribution network and their increasing share in covering consumption.

Data on energy withdrawn from the transmission system by months and suppliers are presented in Figures 7 and 8 respectively.

Figure 7. Energy withdrawn from the transmission network in BIH – monthly data (GWh)

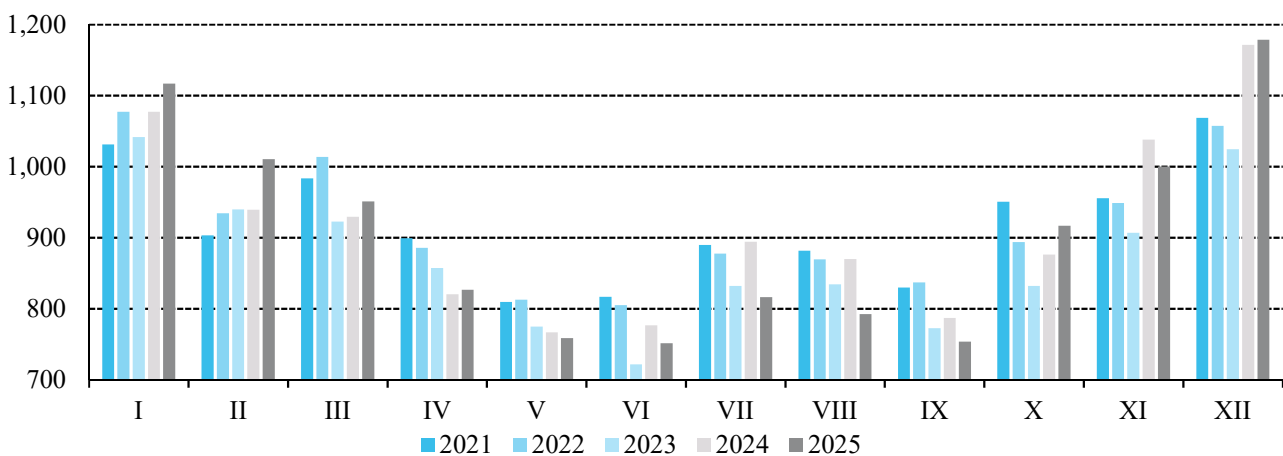

Figure 8. Energy withdrawn from the transmission network in 2025 per supplier (GWh)

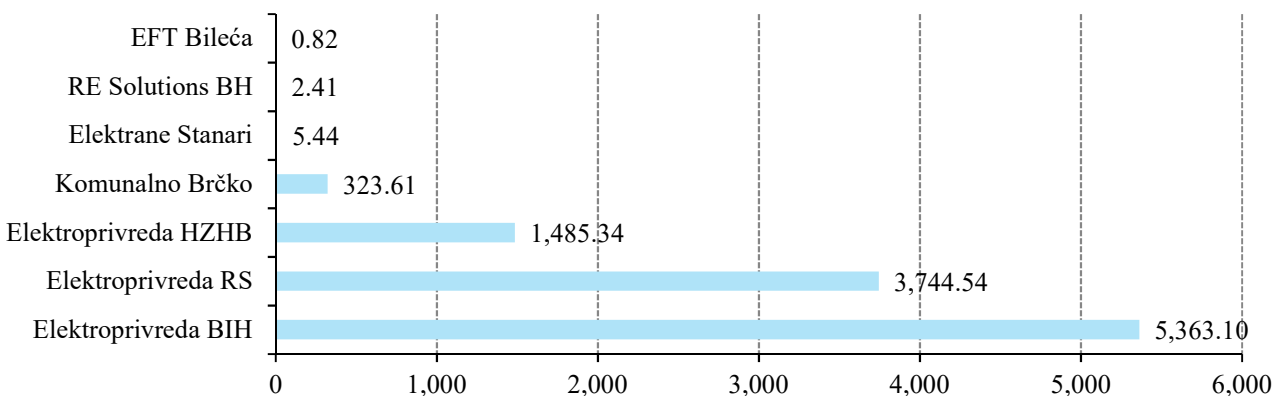
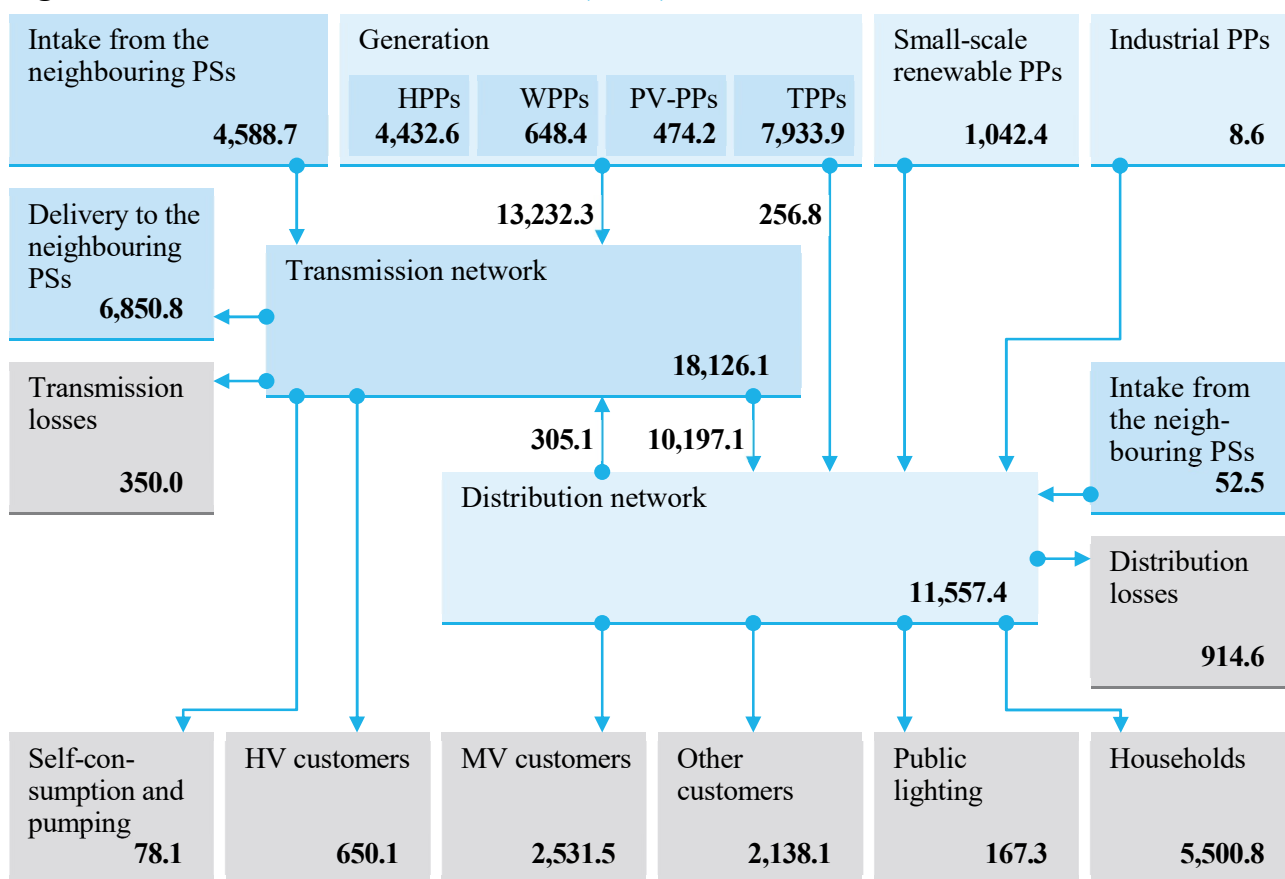

Figure 9. Balance volumes realised in 2025 (GWh)



The difference between total generation and total consumption, that is, the balance surplus in 2025 amounted to 2,210 GWh, which positions Bosnia and Herzegovina in the second place in South East Europe, behind Greece (around 2,500 GWh) and ahead of Bulgaria (1,300 GWh).

An overview of electric power balance volumes realised in 2025 is provided in Figure 9. The detailed balance volumes and electric power indicators of BIH are provided in Annexes C and D respectively.

European Electricity Market

The average annual electricity price for day-ahead market at the Hungarian Power Exchange (HUPX DAM index), after a significant hike in 2022, has been stable over the past three years, ranging within a narrow scope from 100 to 109 EUR/MWh. In 2025, it amounted to 108.51 EUR/MWh, which is 7.6% more than in the previous year (Table 5). Seasonal price fluctuations were within the expected range, with a minimum in the second quarter and a maximum in the first quarter. The other power exchanges in Europe also reported an increase in wholesale electricity prices, so the annual index of the *European Energy Exchange (EEX) for Germany* (EPEX Germany) amounted to 89.32 EUR/MWh in 2025, which

Table 5. Electricity prices at power exchanges (EUR/MWh)

<i>PX indices</i>	<i>Average price</i>	<i>Maximum price</i>	<i>Minimum price</i>
EPEX Germany	89.32	231.36	-0.29
BSP	104.64	231.09	18.85
HUPX DAM	108.51	237.88	21.40
IBEX	106.90	241.89	33.85
SEEPEX	119.78	229.95	36.47
CROPEX	105.35	232.76	18.43

EPEX Germany – European Energy Exchange (EEX) index for Germany
BSP – Slovenian Power Exchange index
HUPXDAM – Day-ahead index of Hungarian Power Exchange (HUPX)
IBEX – Bulgarian Power Exchange index
SEEPEX – Serbian Power Exchange index
CROPEX – Croatian Power Exchange index

Table 6. Electricity generation in the EU (TWh)

<i>Type of power plant</i>	<i>2024</i>	<i>2025</i>	<i>Change (%)</i>
Nuclear power plants	650	652	0,4
Gas-fired power plants	432	466	7,9
Hydropower plants	370	327	-11,6
Coal-fired power plants	271	257	-5,2
Wind power plants	485	473	-2,6
Biomass and biogas	164	162	-1,0
Solar power plants	307	368	19,8
Others	89	86	-3,1
<i>Total</i>	<i>2,767</i>	<i>2,791</i>	<i>0,9</i>

is 13.8% more than in 2024. Traditionally, the lowest average price of 39.70 EUR/MWh was recorded on the Nord Pool Exchange, with a 10.1% increase compared with the previous year.

According to preliminary data for 2025, a 0.5 increase in consumption in the European Union was recorded compared with the previous year. Generation amounted to 2,791 terawatt hours (TWh) and recorded a 0.9% increase, with the largest increase of 19.8% achieved by solar power plants, and with 368 TWh they became the fourth source with a share of 13.2% (Table 6). Generation by wind power plants decreased by 2.6% in spite of a 12 GW increase in capacity, which is a consequence of lower average wind speeds. Hydropower plants also recorded lower generation – due to poor

hydrological conditions their generation decreased by 11.6%. Reduced generation from renewable sources was compensated by increased engagement of gas power plants, which increased generation by 7.9%. Coal-fired thermal power plants reduced generation by 5.2% and with 257 TWh achieved, their share in total generation fell to 9.2%. As in the previous 34 years, nuclear power plants are the largest source with a realisation of 652 TWh and a share of 23.4% in total generation. The largest balance surplus in 2025 was recorded by France with 84 TWh, followed by Sweden with 34 TWh and Spain with 15 TWh. The largest deficit was achieved by Italy with 47 TWh, followed by Germany with 21 TWh and Belgium and Portugal with 14 TWh each.

The dynamic installation of solar power plants continued, the total capacity of which reached 406 GW, with an annual increase of approximately 65 GW. The joint share of wind and solar power plants reached 30.1% in total electricity generation in the European Union, which is in accordance with total electricity sector decarbonisation goals by 2030, i.e. 2035.

In spite of the decrease in their share of electricity generation, fossil fuels show a strong impact on the electricity price trends on wholesale markets, especially in periods with no generation from wind power plants, which have become the second largest source in the EU. Furthermore, there is a significant difference in prices on the exchanges where the Nordic countries, due to their generation portfolio based on hydro, nuclear and wind energy, record significantly lower prices than the prices in the region of West and Central Europe (*Core* region), and the prices in South East Europe in particular, where fossil fuels continue to be dominant.

Regional Electricity Market

The trends on the European Union electricity market reflected also on the market in South East Europe, which is of direct interest to the electric power entities in BIH. An average value of the HUPXDAM day-ahead index, which is dominant in the region, amounted to 108.51 EUR/MWh in 2025 (100.81 EUR/MWh in 2024). Due to the balance deficit and a large share of fossil fuels in electricity generation, wholesale prices in South East Europe were higher than in the other European regions and may be compared only to the prices in Italy. The Western Balkans countries make the biggest contribution to this situation because the decarbonisation process is taking place slowly and dependence on fossil fuels remains high. The exception is Albania which has only renewable sources in its generation portfolio.

An overview of generation and consumption in the region is provided in Table 7, which indicates that the total deficit (difference between generation and consumption) amounted to 19 TWh. This was primarily caused by unfavourable hydrological conditions, for the second year in a row, but also the existing

Table 7. Electricity generation and consumption in the region in 2025 (TWh)

Country	Generation	Consumption	Difference
Albania	7.5	8.3	-0.8
Bosnia and Herzegovina	13.2	10.9	2.3
Bulgaria	37.3	36.0	1.3
Montenegro	2.6	3.8	-1.2
Greece	51.5	49.0	2.5
Croatia	12.9	18.7	-5.8
Kosovo*	5.1	6.2	-1.1
Hungary	34.5	43.7	-9.2
Romania	48.3	52.5	-4.2
North Macedonia	4.4	6.1	-1.7
Slovenia	12.8	12.4	0.4
Serbia	32.7	34.2	-1.5
<i>Total</i>	262.8	281.8	-19.0

* This designation is without prejudice to positions on status, and is in line with the United Nations Security Council Resolution 1244 and the International Court of Justice Opinion on the Kosovo Declaration of Independence.

weaknesses in the operation of coal-fired thermal power plants in the Western Balkans countries. Poor hydrology was particularly noticeable in the first half of the year, and, consequently, the prices increased in that period which in January and February averaged around 150 EUR/MWh. On the other hand, there was a noticeable pattern in the second and third quarter when significant volumes of electricity produced by solar power plants were imported at extremely low prices during midday hours.

The implementation of the *EU Emissions Trading System*, with the existing wholesale prices, is the reason for an accelerated coal phase-out in electricity generation. This trend has been present in Romania and Greece, and since 2023 is also registered in Bulgaria and Slovenia. The daily price peaks recorded from 19:00 to 22:00 hrs enable profitable operation from flexible sources such as gas-fired power plants making Greece the larger exporter in the region. At the same time, a number of solar power plants is built, so these capacities reached the significant levels in some countries (Greece 11 GW, Hungary 9 GW, Slovenia 6 GW). The problems with coal exploitation and availability of thermal blocks are still present (Bosnia and Herzegovina, Serbia, North Macedonia, Kosovo*). Serbia and North Macedonia imported the missing quantities, while in Bosnia

and Herzegovina, generation in thermal power plants further decreased recording the lowest level over the past two decades. Unlike the European Union, where the installed capacity of wind and solar power plants has been increasing significantly, the pace of this process in the Western Balkans countries does not guarantee the fulfilment of energy transition goals towards clean energy.

Electricity Market in Bosnia and Herzegovina

In 2025, total electricity consumption in Bosnia and Herzegovina amounted to 12,330 GWh or 1.6% more than in the previous year. Customers connected to the transmission system withdrew 650 GWh or 24.4% less, while customers connected to the distribution system withdrew 11,252 GWh, with a 3.2% increase compared with the previous year. Of this amount 10,337 GWh pertain to the withdrawal by end customers and 915 GWh to losses in the distribution network. Total sale to end customers amounted to 10,988 GWh, which is a 1.5% increase.

At the end of the year, the number of electricity customers in BIH reached 1,623,816, of which 1,490,729 are households and 133,087 customers in all other consumption categories (Table 8).

The competent regulatory commissions do not to set tariff rates for those consumption categories which cannot be regulated any longer under the applicable legislation. With the end of 2014, regulation of supply tariffs for all customers was abolished except for households and customers belonging to the category of ‘other consumers’ (commercial customers at 0.4 kV). Since 1 January 2015, all customers in BIH have the possibility to choose their suppliers on the market. Customers that do not choose their supplier on the market may be supplied by public suppliers at public supply prices, while households and small customers may be supplied within the public, that is, universal service at regulated prices.

In 2025 the option of being supplied within the universal service was used by almost all households and most of the customers belonging

Table 8. Number of electricity customers in BIH by consumption category

<i>Supplier</i>	<i>110 kV</i>	<i>35 kV</i>	<i>10 kV</i>	<i>Other consumers (market-based supply)</i>	<i>Other consumers (public supply)</i>	<i>Households</i>	<i>Public lighting</i>	<i>Total</i>
Elektroprivreda BIH	18	66	1,010	21,028	49,061	750,308	5,163	826,654
Elektroprivreda RS	5	30	1,059	4,656	26,005	518,786	95	550,636
Elektroprivreda HZHB	3	4	356	4,775	13,112	188,058	2,258	208,566
Komunalno Brčko		1	86	373	3,461	33,577	458	37,956
Other suppliers			1	3				4
Total	26	101	2,512	30,835	91,639	1,490,729	7,974	1,623,816

to the category of ‘other consumers.’ An average electricity price for these customers amounted to 8.57 euro cents/kWh and it was 4.5% higher than in 2024 when it amounted to 8.21 euro cents/kWh.

An average price for households amounted to 8.28 euro cents/kWh (a 6.7% increase), while an average price for small customers under the category of ‘other consumers,’ that are supplied under the public, that is, universal service, was 11.00 euro cents/kWh or 9.0% higher compared with 2024. The average electricity prices for end customers in BIH are presented in Figure 10, while Figure 11 gives an overview of average electricity prices per public suppliers in 2025.

The Regulatory Commissions in BIH work on the gradual elimination of inherited cross-subsidies among some categories of electricity customers, which is done in accordance with best international regulatory practice in order to avoid so-called ‘tariff shocks.’ The trend of changing the ratio of the average prices between small commercial customers and households is visible in Figure 10. According to the 2025 data, cross-subsidies between these categories amount to 32.8% on average, with the lowest values recorded among the customers supplied by Komunalno Brčko (11.5%), while the highest values were recorded among the customers supplied by Elektroprivreda RS (38.0%). There is an obvious need for further

Figure 10. Average electricity prices by customer category, excluding VAT (euro cents/kWh)

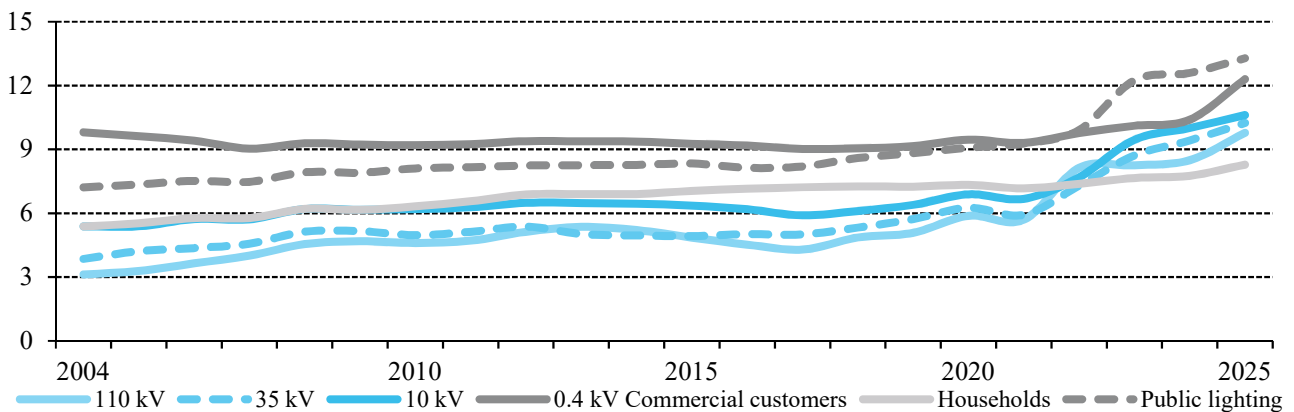
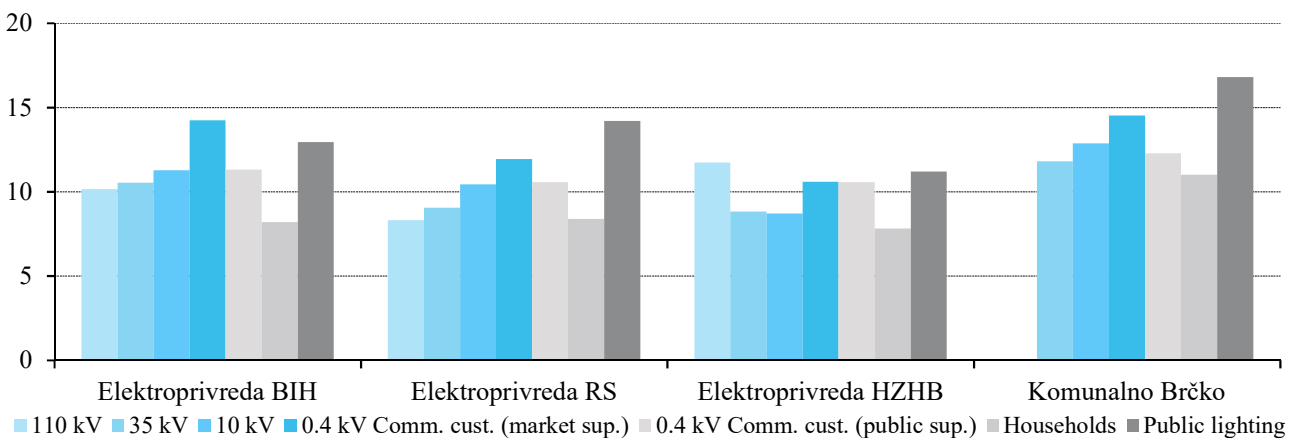

Figure 11. Average electricity prices by public utility, excluding VAT (euro cents/kWh)



reduction of cross-subsidies, thus complying with the basic regulatory principle of reflecting real costs in price formation.

In 2025, the largest number of customers was supplied by their traditional suppliers (the so-called ‘incumbents’). A significant increase in wholesale prices decreased competition on the retail market, so, in addition to the incumbents, three more suppliers were active on the retail market: HEP Energija d.o.o., Mostar, Petrol BH Oil Company d.o.o., Sarajevo and Energy Financing Team d.o.o., Bileća. They supplied only a small part of the customers connected to the medium voltage network and the customers falling under the category ‘other consumers,’ to whom they delivered a total of 18 GWh. The incumbents supplied all the customers connected to the transmission system and the largest part of the customers connected to the distribution system.

In conclusion, in 2025 a total of 18.00 GWh was delivered to customers that switched suppliers, or only 0.16% of total energy withdrawn by end customers in BIH. In the previous period, tens of thousands of customers changed the conditions of supply by modifying the contract with their previous traditional suppliers, thus choosing on the open market the supply offer that suited them best.

A total of 6,151.27 GWh (56.0% of total consumption by end customers) was delivered to the customers supplied within the public, that is, universal service, while 4,836.44 GWh (44.0%) was delivered to the customers for whom prices are not regulated.

Trading on the wholesale market in Bosnia and Herzegovina, which is based on bilateral sales contracts between suppliers, is significantly more dynamic (Figure 12). Although this market has not been institutionalised yet (there is no either market operator or power exchange), the result of numerous bilateral contracts is significant – a total of 21 active licensed entities traded 4,536 GWh on the internal market. Furthermore, cross-border transactions

Figure 12. Overview of trading on the wholesale market in BIH in 2025 (MWh)

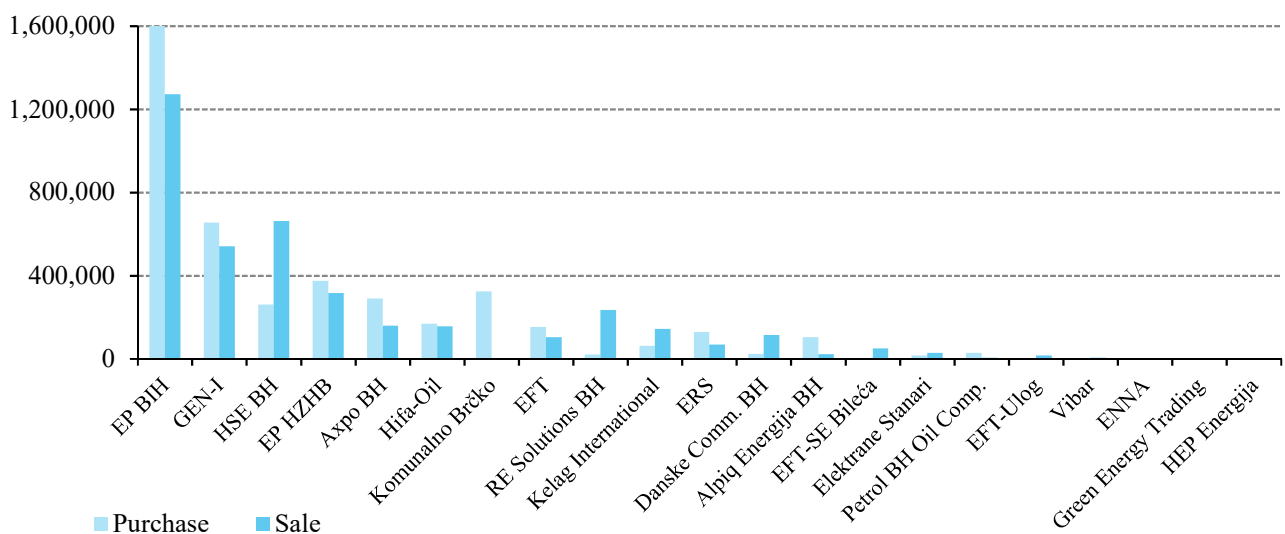

were also registered totalling 7,872 GWh, of which exports amounted to 5,100 GWh while imports amounted to 2,772 GWh.

In addition to the wholesale and retail markets, in Bosnia and Herzegovina the balancing market operated by NOS BIH is also functional. Essentially, it is a monopsony market, where on the demand side there is only one entity – NOS BIH, while on the supply side there are mostly generators providing ancillary services. The calculation of deviations (imbalances) of balance responsible parties from the daily schedule is also conducted on the balancing market in terms of energy and prices. Imbalance prices are determined based on prices of balancing energy on an hourly basis. All transactions between suppliers on one side and NOS BIH on the other are conducted based on the market principles through annual and monthly bids while prices of the balancing energy are formed a day ahead through offers by suppliers on an hourly basis.

The total value of ancillary services purchased on the balancing market in 2025 amounts to EUR 61.76 million, of which EUR 35.29 million pertains to the purchase of energy to cover losses in the transmission system, EUR 7.94 million to payment of deviations towards the SHB Load Frequency Control Block (SHB LFC Block) – the so-called *FSKAR* calculation, and EUR 18.53 million to payment of balancing capacity and balancing energy (Table 9).

The upward balancing energy was activated in an amount of 74.26 GWh (of which 3.21 GWh pertain to positive frequency containment reserve – FCR, 50.69 GWh to automatic frequency restoration reserve – aFRR and 20.36 GWh to manual frequency restoration reserve – mFRR). The downward balancing energy was activated in an amount of 41.83 GWh (of which 2.72 GWh pertain to negative FCR, 31.84 GWh to aFRR and 7.27 GWh to mFRR). As far as imbalances of the balance responsible parties are concerned, deviations in the direction of deficit (shortage) and the direction of surplus (excess) were recorded totalling 121.32 GWh

Table 9. Values of purchased ancillary services

Ancillary Services	2024 (EUR)	2025 (EUR)	Difference (%)
FCR – capacity	431,073	474,362	10.0
aFRR – capacity	3,087,973	2,545,887	-17.6
mFRR – capacity	3,598,063	3,376,513	-6.2
‘Upward’ balancing energy	10,711,085	13,173,043	23.0
‘Downward’ balancing energy	-2,357,588	-1,040,293	-55.9
Losses in the transmission system	31,168,037	35,290,433	13.2
Deviations towards SHB LFC Block (<i>FSKAR</i> calculation)	6,431,572	7,941,263	23.5
Total	53,070,215	61,761,209	16.4

(88.82 GWh in 2024) and 52.79 GWh (41.71 GWh in the previous year) respectively, which resulted in a deficit towards SHB LFC Block amounting to 68.53 GWh. In this case, the average imbalance prices reached 114.08 EUR/MWh (157.28 EUR/MWh in the previous year) and 39.10 EUR/MWh (45.44 EUR/MWh in the previous year) for energy deficit and surplus respectively.

By the provision of system service, from suppliers withdrawing energy from the transmission system and through the calculation of deviations from the daily schedule by balance responsible parties, NOS BIH made revenue of EUR 59,617,401, of which EUR 26,751,318 and EUR 32,866,082 were collected for the system service tariff and imbalances respectively. Furthermore, exports and imports of cross-border balancing services were registered amounting to EUR 309,805 and EUR 367,844 respectively.

In comparison to 2024, the prices of balancing energy both in the direction of deficit and surplus decreased. However, the poor hydrological conditions and problems with the operation of thermal power plants as well as a strong pace of connecting new solar and wind power plants resulted in an increase of deviations from daily schedules by the balance responsible parties, so imbalances increased in physical terms. Although a decrease in imbalance prices was recorded in both directions, significant physical growth of imbalances led to their increase in financial terms by 35.8%.

Cross-Border Trade

Good connections of the BIH system with the neighbouring electric power systems enable a high level of cross-border electricity exchange. Electricity exports increased, so in 2025 a total of 5,137 GWh was exported, which is 13.5% more than in the previous year. A total of 17 entities exported electricity, among which Elektrane Stanari d.o.o., Stanari with 1,960 GWh was the

Figure 13. Overview of cross-border transactions by company in 2025 (MWh)

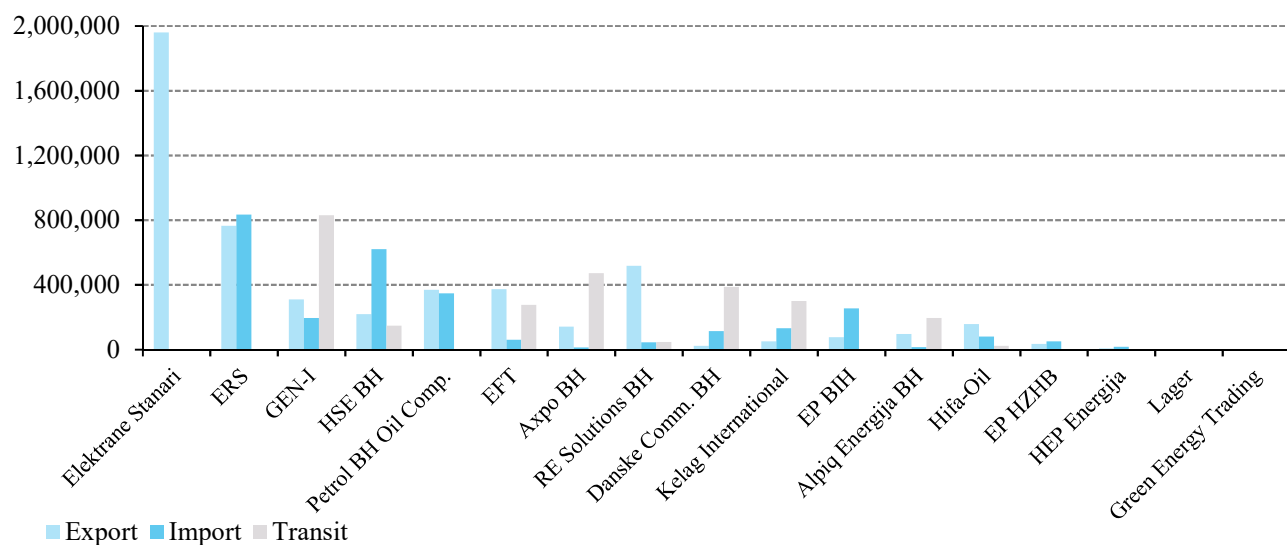

Table 10. Cross-border trade per border, including registered transits (GWh)

Country	Exports	Imports
Croatia	2,001.3	3,233.1
Serbia	3,538.3	1,578.2
Montenegro	2,235.7	636.4
<i>Total</i>	<i>7,775.3</i>	<i>5,447.7</i>

leader in terms of the export scope, followed by MH Elektroprivreda Republike Srpske – Parent Company, a.d., Trebinje with 764 GWh, Renewable Energy Solutions BH with 517 GWh, EFT Bileća with 373 GWh, Petrol BH Oil Company d.o.o., Sarajevo with 370 GWh, GEN-I d.o.o., Sarajevo with 309 GWh etc.

Electricity imports amounted to 2,810 GWh, which is a 39.0% increase compared to the previous year. Among the 14 entities importing electricity, the highest realisation was achieved by MH Elektroprivreda Republike Srpske – Parent Company, a.d., Trebinje (834 GWh), HSE BH Energetsko preduzeće d.o.o., Sarajevo (620 GWh), Petrol BH Oil Company (347 GWh), JP Elektroprivreda Bosne i Hercegovine d.d., Sarajevo (253 GWh) etc. An overview of cross-border transactions by company in 2025 is provided in Figure 13. The largest scope of cross-border electricity trading was achieved on the border with Croatia followed by Serbia and Montenegro (Table 10).

In 2025, registered electricity transits through the BIH transmission system amounted to 2,638 GWh, which is 278 GWh or 9.5% less than in the previous year. Data on transit flows are used as the basic element to calculate revenues and expenditures within the *Inter-TSO Compensation Mechanism* (ITC mechanism). As the calculation of the ITC mechanism is significantly delayed due to a complex procedure, the complete data for 2024 were published only in the middle of 2025. According to these data, the expenditures of BIH amount to a total of EUR 406,346, which is significantly less than in 2023 when they amounted to EUR 8,666,786. The positive trend continued in 2025, so in the first nine months the revenues amounted to EUR 1,432,148. According to the rules, increased transit flows increase revenues, while increased import and export flows increase expenditures.

The total revenue of BIH based on the auctions for allocation of cross-border transmission capacity on an annual basis, which were held at the beginning of December 2025 for the upcoming year, amounts to EUR 7,795,524, which is 44.3% less compared with the previous year (Table 11). The reduced demand, and, consequently, the revenue based on the allocation of cross-border capacities was affected by the *Carbon Border Adjustment Mechanism* (CBAM), which is applied from January 2026.

Table 11. Revenues generated from annual auctions

Year	Revenue (EUR)	Year	Revenue (EUR)
2017	1,033,461	2022	4,046,638
2018	599,097	2023	8,777,301
2019	1,372,254	2024	7,482,958
2020	1,332,094	2025	13,984,026
2021	1,806,487	2026	7,795,524

The highest price was reached on the border with Serbia amounting to 5 EUR/MWh for 150 MW of transmission capacity in the direction from Bosnia and Herzegovina. In the direction from BIH to Montenegro (for capacity of 200 MW) the price of 3.44 EUR/MWh was reached, while in the direction towards Croatia the capacity of 400 MW was allocated at the price of 0.16 EUR/MWh, as the CBAM mechanism is implemented on the borders towards the European Union. On all borders in the direction towards BIH, the prices for the same amounts of offered capacities ranged from 0.27 EUR/MWh to 0.49 EUR/MWh.

Figure 14 provides an overview of revenues based on monthly auctions per border and direction. In 2025, these revenues increased by 10.7% amounting to EUR 9,871,793. Daily and intraday auctions of cross-border transmission capacities in 2025 resulted in the revenues of EUR 970,061, which is 54.7% less than the realisation in the previous year.

In accordance with the rules, Elektroprenos Bosne i Hercegovine is the user of all revenues based on the allocation of the right to use cross-border transmission capacities as well as the revenues, that is, expenditures, achieved by the application of the Inter-TSO compensation mechanism (ITC Mechanism).

Figure 14. Revenues based on monthly and daily auctions, per border and direction (EUR)

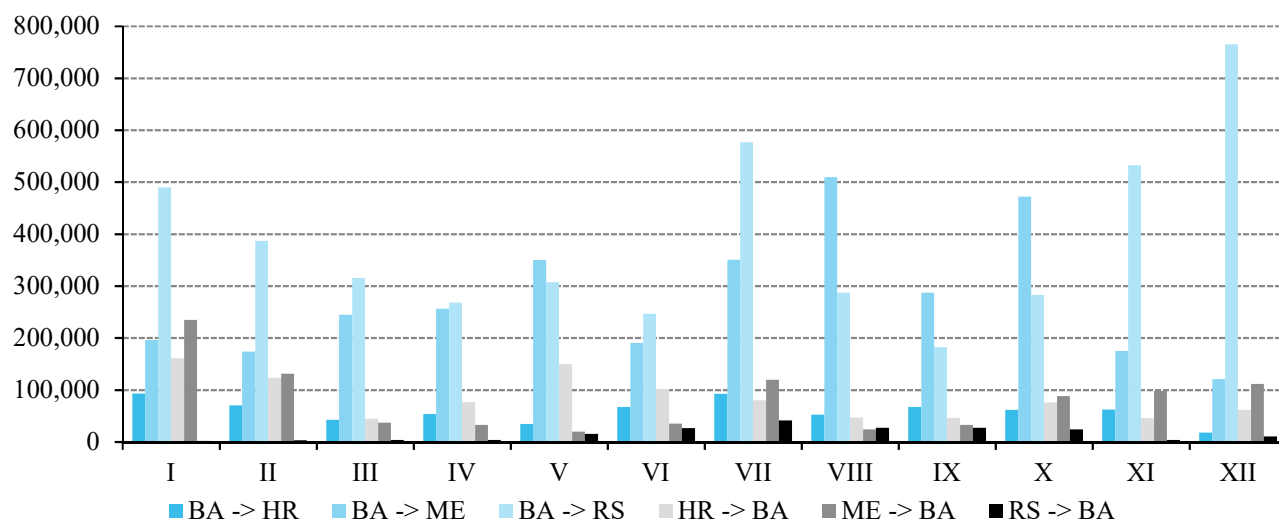

3.8 Energy Statistics

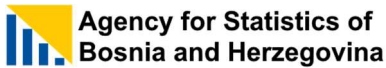

Aware of the relevance of objective presentation of data on energy volumes and electricity prices, in 2025 SERC continued to pay particular attention to enhancing its performance in the segment of energy statistics. The key partner in the exchange of energy volumes and data is the Agency for Statistics of Bosnia and Herzegovina (BHAS) with which SERC has been cooperating for many years, in particular with regard to fulfilling the reporting requirement of international bodies in line with prescribed methodologies and reporting dynamics. The cooperation between the two institutions contributes to energy statistics development and harmonisation of the BIH official system of statistics with statistics of the EU countries in all fields, in particular in the field of energy statistics.

Figure 15. Electricity prices expressed in EUR/kWh for households (annual consumption from 2,500 to 5,000 kWh) in the first half of 2025, using Eurostat methodology

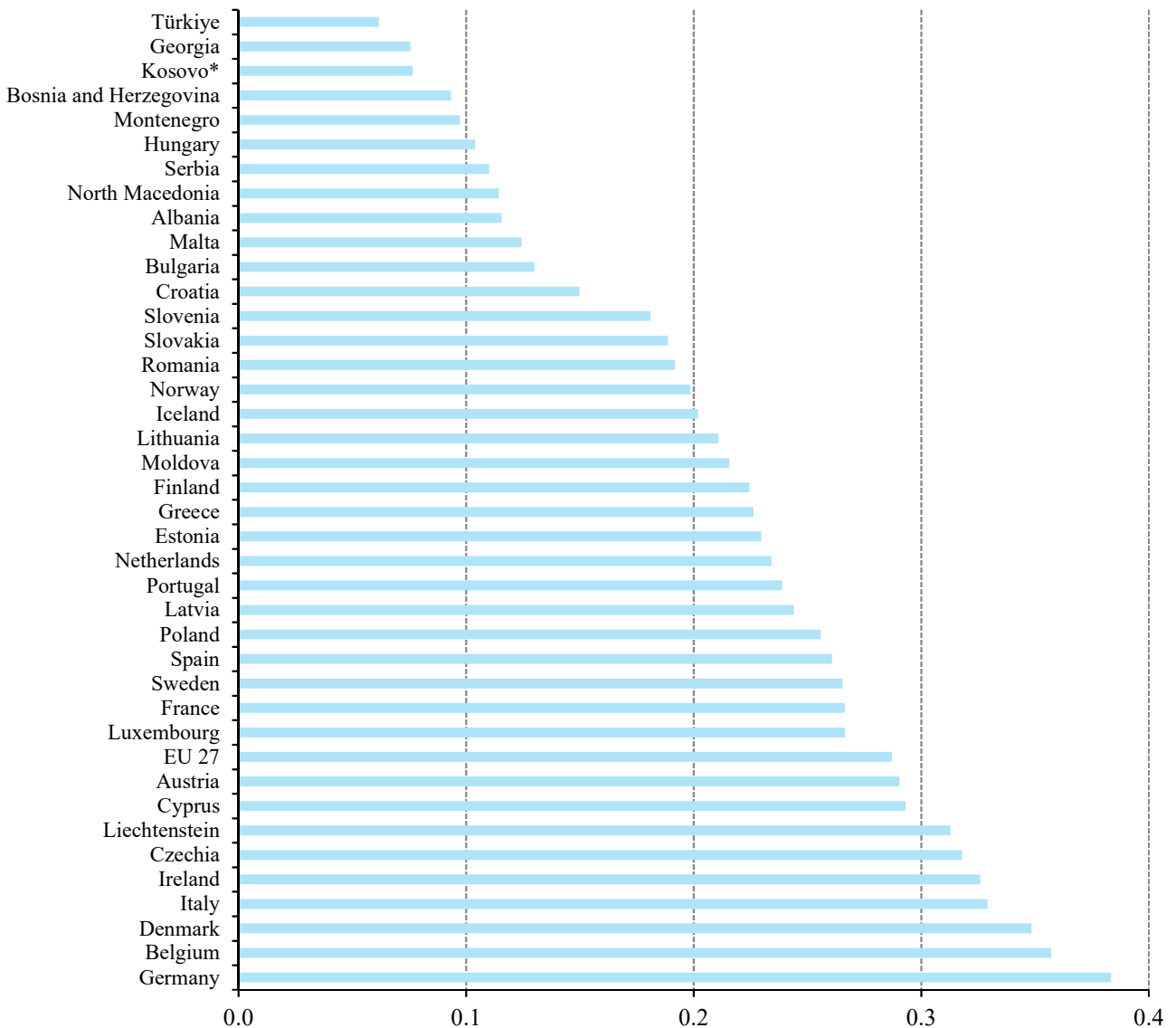

Note: All taxes and levies included

Figure 16. A geographic overview of electricity prices for households (in EUR/kWh) in the first half of 2025, using Eurostat methodology

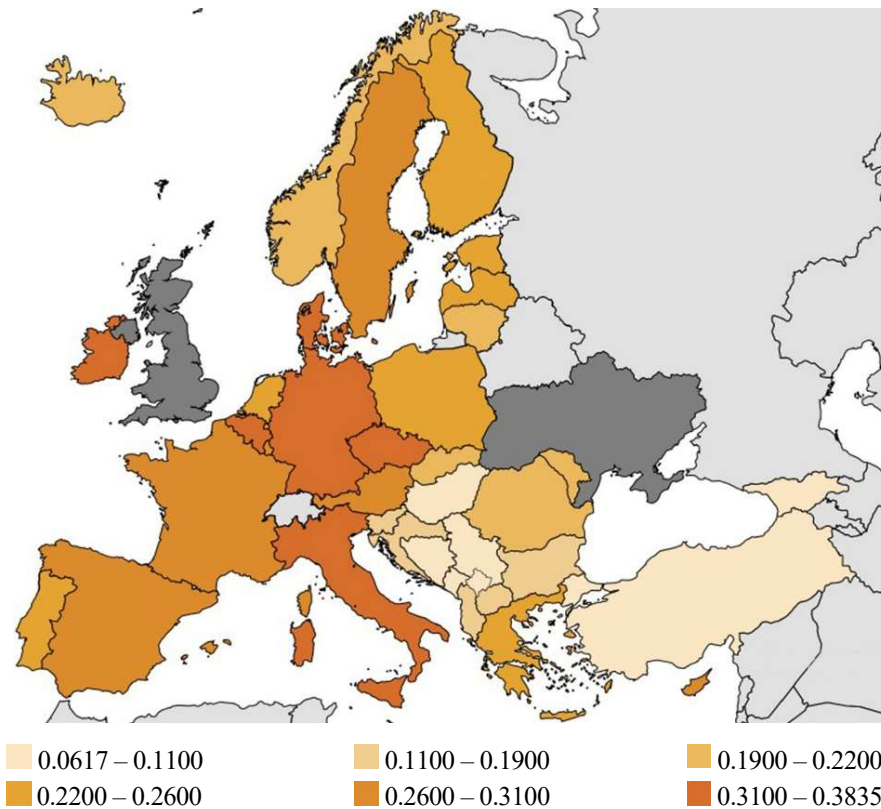
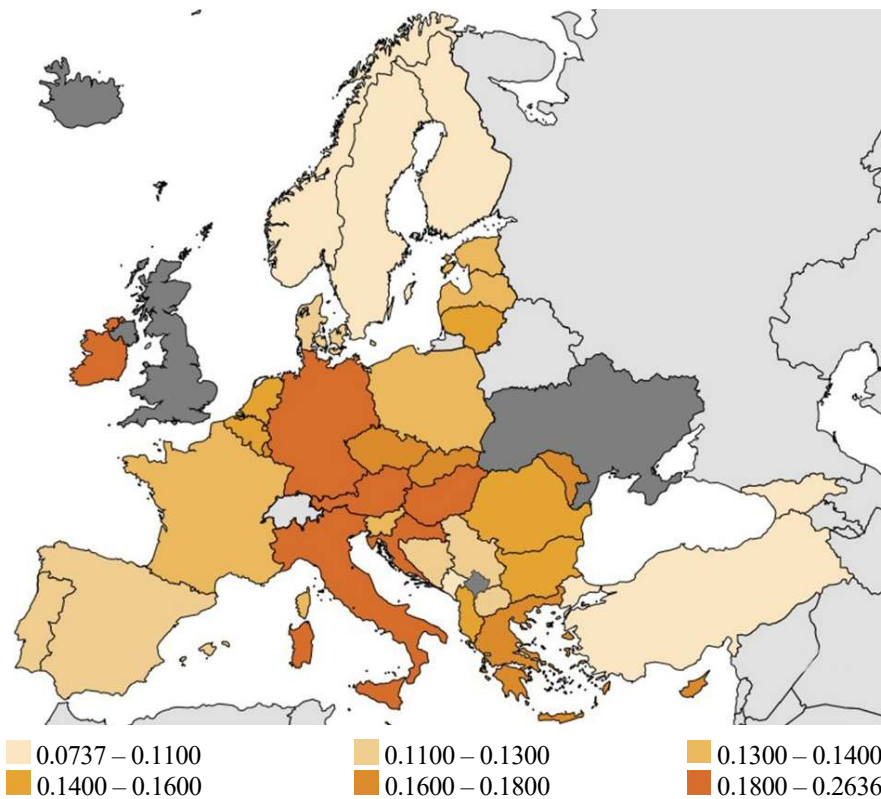

Figure 17. A geographic overview of electricity prices for industrial customers (in EUR/kWh) in the first half of 2025, using Eurostat methodology



Eurostat is the statistical office of the European Union situated in Luxembourg. Its task is to provide the European Union with statistics at European level that enable comparisons between countries and regions.

The results of cooperation between the two institutions are recognisable in Eurostat’s reports, which include data on electricity prices in Bosnia and Herzegovina since 2011, thus enabling comparison with EU Member States and some countries in the EU accession process (Figures 15 – 18).

In addition to analysing data on the BIH electric power sector, SERC continuously collects and analyses data on regional markets, including data on the power exchanges based in Leipzig, Budapest, Sofia, Belgrade, Ljubljana and Zagreb (Table 5).

Based on a systematic approach to numerous electric power indicators, SERC also provided quality answers to a number of inquiries from national and international institutions in 2025 by presenting statistical data on the electric power sector of Bosnia and Herzegovina.

Figure 18. Electricity prices expressed in EUR/kWh for industrial customers (annual consumption from 500 to 2,000 MWh) in the first half of 2025, using Eurostat methodology

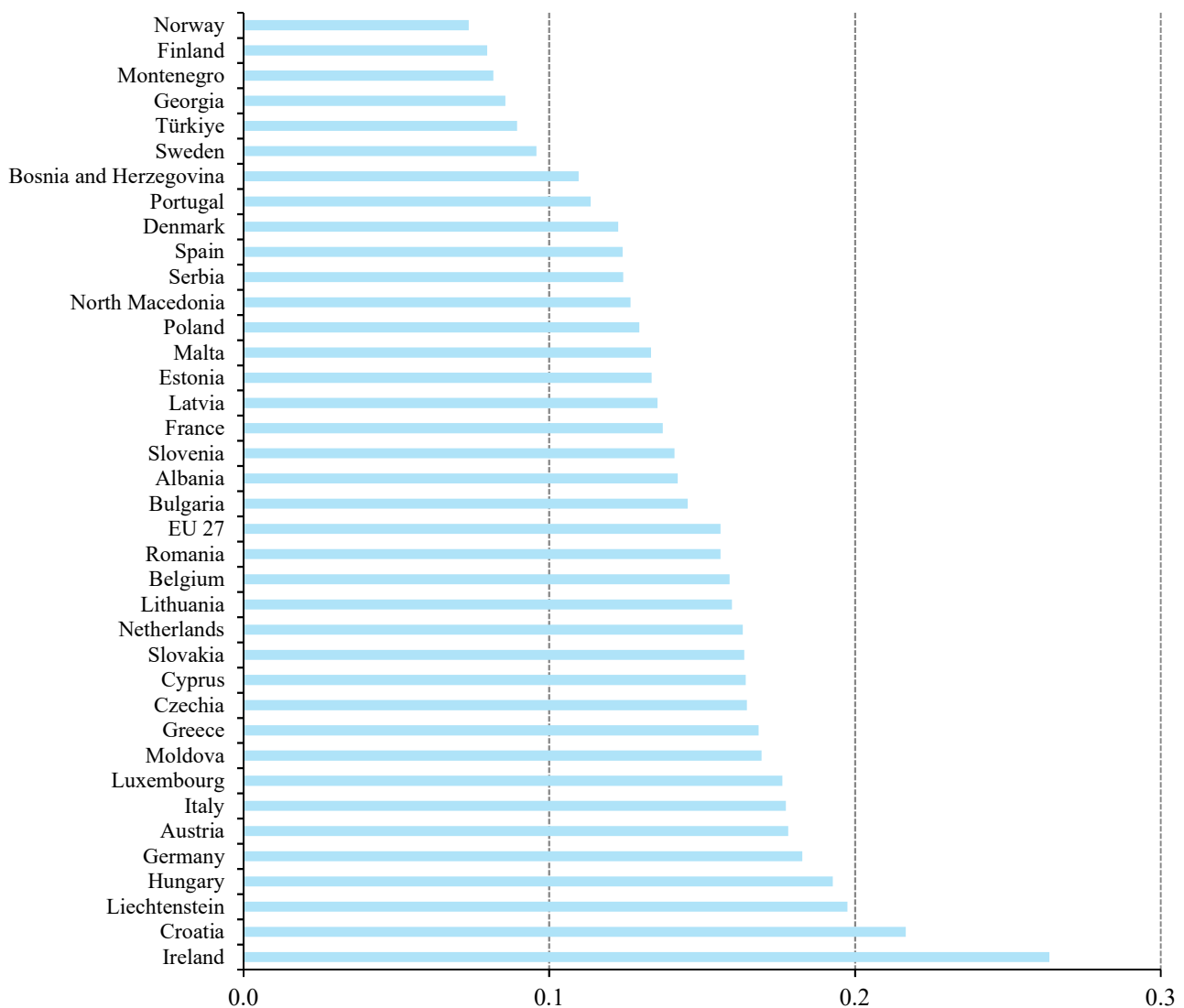

Note: All taxes and levies excluded

3.9 Judicial and Other Disputes

All six judgements of the Court of Bosnia and Herzegovina so far have confirmed the lawfulness of the SERC decisions that were disputed before court by the legal persons whose applications were decided upon after the completion of the tariff proceedings or dispute settlement procedures. In 2025, there were no new applications for revision of any decision from the SERC regulatory practice by any person that has standing to commence an action.

One of the regulatory specifics is the adjudicative function of the regulator, that is, the competence to resolve disputes among the users and service providers in the regulated sector. Pursuant to the *Law on Transmission of Electric Power, Regulator and System Operator of Bosnia and Herzegovina*, part of competences and powers of the State Electricity Regulatory Commission includes dispute resolution pertaining to the transmission system. In 2025, only one incomplete request for dispute resolution was submitted, which the applicant did not complete following the SERC invitation, which is the reason why the procedure was not conducted.

In addition to directly ensuring the right to fair and non-discriminatory access to the transmission network and the active protection of customers through dispute resolution, the State Regulatory Commission makes every effort to act in an educative and preventive manner and these efforts significantly prevent these disputes. The preventive activities are carried out in several ways – by monitoring the regulated entities and the quality of services they provide, by collecting, analysing and processing data on rules and actions of the regulated entities with regard to access to the transmission network and the protection of customers and by the active participation of SERC representatives in creating various platforms and educative tools for system users and electricity customers.

3.10 Other Key Activities

The State Electricity Regulatory Commission continued to actively exchange data with the key state institutions in 2025, including the Council of Ministers of Bosnia and Herzegovina, Ministry of Foreign Trade and Economic Relations of BIH, Directorate for European Integrations of the Council of Ministers of BIH, Competition Council of BIH and BIH Agency for Statistics,⁶ and prepared different types of information they needed. SERC gave a particular contribution to activities of the Stabilisation and Accession Committee and a Subcommittee on Transportation, Environment, Energy and Regional Development. In line with its legal powers to

⁶ The State Electricity Regulatory Commission signed Memoranda of Understanding with the Agency for Statistics of BIH and the Competition Council of BIH on 19 April 2011 and 28 May 2014 respectively.

act in the area of Brčko District of BIH as a regulatory authority, through its activities SERC also cooperates with the Brčko District Government.

Since their establishment, the State Regulatory Commission and Entity Regulatory Commissions – the Regulatory Commission for Energy in the Federation of Bosnia and Herzegovina (FERK) and the Regulatory Commission for Energy of Republika Srpska (RERS) cooperate and harmonise their activities.

SERC continues its active engagement in the reform and the development of an EU-*acquis* compliant legislative framework for electricity. In this process, based on the obtained regulatory experience in the implementation of laws in the electricity sector and previous education and cooperation with the relevant international institutions, SERC expressed its commitment to provide support and concrete assistance in the fulfilment of obligations of Bosnia and Herzegovina through various normative activities.

At the request of the Ministry of Foreign Trade and Economic Relations of BIH, which is the competent authority for policy creation under the *Law on Transmission of Electric Power, Regulator and System Operator of BIH*, SERC nominated its representatives for the *Working Group for continuation of activities on the development and harmonisation of the Law on Electricity and Natural Gas Regulator, Transmission of Electric Power and Electricity Market in Bosnia and Herzegovina*⁷ (in 2023), as well as the *Working Group for transposition and implementation of Regulation (EU) 2022/869 on guidelines for trans-European energy infrastructure* (in 2024). SERC expects that the development and adoption of the new state law will complete the transposition of the *Third EU Energy Package* and the *Clean Energy for All Europeans Package*, i.e., the *Energy Integration Package (EIP)*, which was completed in the Energy Community with the obligation to transpose its content into national legislation and ensure implementation by the end of 2023 (please see Section 4.1 and Annex E).

Acting in line with its competence, SERC supports the development of an *Integrated Energy and Climate Plan of Bosnia and Herzegovina (NECP)*. The Ministry of Foreign Trade and Economic Relations of BIH together with the relevant entity ministries is in charge of its development. SERC participated in the activities of an intradepartmental working group established to develop this plan as well as in activities of the Energy Efficiency Task Force, Task Force on Renewables and the Security of Supply and Internal Energy Market Task Force. The draft NECP was submitted to the Energy Community Secretariat for its review on 30 June 2023. At the end of December of the same year, pursuant

⁷ The title of this law was changed during its development. At the time of writing this report, the *Draft Law on the Regulator, Transmission and Electricity Market in Bosnia and Herzegovina*, was in the process of being adopted by the Parliamentary Assembly of Bosnia and Herzegovina.

to Article 9 of Regulation (EU) 2018/1999 on the governance of the energy union and climate action, the Secretariat assessed the draft Plan and provided its detailed recommendations. Bosnia and Herzegovina was invited to amend its content and adopt the final NECP and submit it to the Secretariat by 30 June 2024. On 18 December 2025, the Energy Community Ministerial Council invited once again Bosnia and Herzegovina to submit its final NECP, pursuant to Regulation (EU) 2018/1999.

SERC also provides significant support within the *Program of Integration of Bosnia and Herzegovina into the European Union*, through active participation in the activities under Chapter 15 – Energy, Chapter 21 – Trans-European Networks, and Chapter 28 – Consumer and Health Protection.

Acting as a national regulator in representing the interests of BIH, SERC participated in several local and regional projects in 2025.

In 2025 SERC representatives actively participated in the three-year project implemented by the German Agency for International Cooperation (*Deutsche Gesellschaft für Internationale Zusammenarbeit – GIZ*) *Community Action for Energy Transition in Bosnia and Herzegovina*, which was launched in June 2023 as well as in the GIZ regional three-year project *Green Agenda: Decarbonisation of the Electricity Sector in the Western Balkans* which was implemented since November 2022.

In accordance with its competences, the State Electricity Regulatory Commission participated in the implementation of the five-year *Energy Policy Activity (EPA)*, launched on 1 October 2024 by the United States Government with a view to strengthening energy security of Bosnia and Herzegovina and accelerating energy sector reform. The project focuses on electricity, natural gas, energy security, renewable energy, energy efficiency, e-mobility, legal and regulatory framework, cybersecurity and digitalisation, and public outreach. The *Energy Policy Activity* is implemented through cooperation and support for an open dialogue with decision-makers, leaders in the energy sector, the private sector, non-governmental organisations, the media, and citizens in order to implement key reforms needed to build a more resilient, diversified, and sustainable energy sector. In this context, in 2025 a number of analyses, recommendations and other documents were developed with direct participation of SERC representatives.

At all administrative levels in Bosnia and Herzegovina, in line with respective constitutional competences it is necessary to continue in the forthcoming period the alignment of energy legislation with the European Union *acquis*, integrated development of energy and climate policies and the implementation of the energy sector reform. The requirements of the European Union in the energy sector are to the greatest extent included in the provisions of the *Treaty establishing the Energy Community*.

4. ACTIVITIES IN INTERNATIONAL INSTITUTIONS

4.1 Energy Community



The Treaty establishing the Energy Community, which was signed in Athens on 25 October 2005, and came into effect on 1 July 2006, provides for the creation of the biggest internal market in the world for electricity and gas, with effective participation of the European Union on one side, and the following nine Contracting Parties (CPs): Albania, Bosnia and Herzegovina, Georgia, Kosovo*, Moldova, Montenegro, North Macedonia, Serbia and Ukraine.⁸

In accordance with the expression of interest, the following countries participate in the work of the Energy Community bodies: Austria, Bulgaria, Croatia, Cyprus, Czechia, Finland, France, Germany, Greece, Hungary, Italy, Latvia, Lithuania, the Netherlands, Poland, Romania, Slovakia, Slovenia and Sweden. These 19 countries have the status of Participants and directly participate in the work of the Energy Community bodies; in the voting procedure their positions are expressed by votes of the European Commission.

By signing the Treaty, the Contracting Parties from the region are obligated to establish a common electricity and gas market that will operate in accordance with the standards of the EU energy market into which it will integrate. It is to be achieved by gradual transposition of the EU *acquis*, which means the implementation of the relevant EU directives and regulations pertaining to electricity, gas, security of supply, oil, environment, renewables, energy efficiency, infrastructure, competition and statistics (Annex E).

To ensure an adequate process of establishing and functioning of the Energy Community, the following institutions were established: Ministerial Council, Permanent High Level Group, Regulatory Board and Secretariat. Whereas the Electricity Forum (Athens Forum) and the Gas Forum were established by the Energy Community Treaty, the Oil Forum was established by a Ministerial Council Decision in 2008. The additional fora, such as the Law Forum, Dispute Resolution Forum and Just Transition Forum convene on the basis of the Secretariat's initiative.

The Energy Community was initially established for a 10-year period. The Treaty was extended on two occasions for a ten-year period, in October 2013 and December 2023. Consequently, the Treaty Establishing the Energy Community is valid until 30 June 2036.

⁸ The list shows the Contracting Parties on 31 December 2025. Moldova, Ukraine and Georgia have Contracting Party status as of 1 May 2010, 1 February 2011 and 1 July 2017 respectively.

When the Treaty entered into force, Bulgaria and Romania were also the Contracting Parties which joined the European Union on 1 January 2007 as well as Croatia which is an EU Member State as of 1 July 2013.

The main goals of the Energy Community are the creation of a stable and single regulatory framework and market space that ensures reliable energy supply and attracts investments in the electricity and gas sectors. In addition, it assumes the development of alternative sources of gas supply and improvement of the environment, with the implementation of energy efficiency and the utilisation of renewable sources.

Figure 19. Geographic scope of the Energy Community

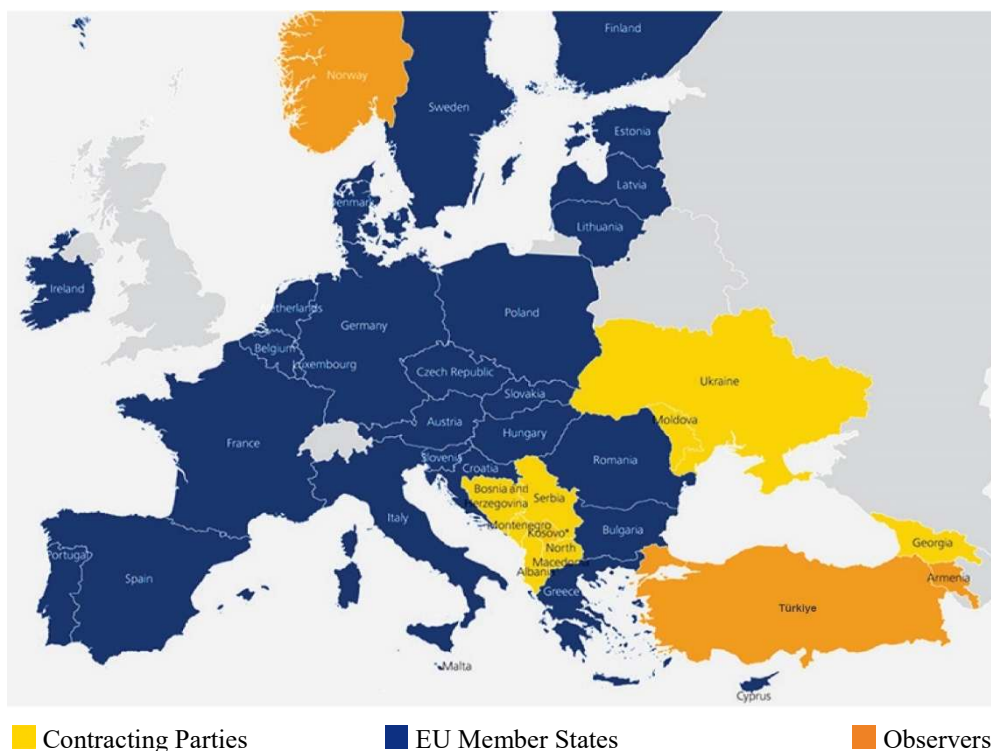

The 20th anniversary of the Energy Community was marked at an informal meeting of the Ministerial Council held on 17 July 2025 in Athens. In the past period, the Energy Community has grown into an organisation which provides a solid institutional framework for cooperation, mutual support and exchange of experiences and, therefore, serves as a model for regional cooperation on energy matters.

The Energy Community Ministerial Council held its annual meeting on 18 December 2025. On that occasion, Decision 2025/09/MC-EnC was adopted amending Annex I to the Energy Community Treaty and adapting to and adopting in the Energy Community Regulation (EU) 2017/1938 as amended by Regulation (EU) 2025/1733 of the European Parliament and of the Council as regards the role of gas storage for securing gas supplies ahead of the winter season.

At this meeting it was concluded that at the same time as gas market integration is gaining momentum, several Contracting Parties are approaching a decisive stage in electricity market integration ahead of accession, having fully or nearly transposed the *Electricity Integration Package (EIP)*. Subject to verification of compliance by the European Commission, this progress opens the door to electricity market coupling with the EU internal market ahead of accession. In this context, Ministers underlined that the *Carbon Border Adjustment Mechanism (CBAM)*,⁹ entering into

⁹ Please see Regulation (EU) 2023/956 of the European Parliament and of the Council of 10 May 2023 establishing a carbon border adjustment mechanism.



Dan Jørgensen, European Commissioner for Energy and Housing:

“It has been a year of progress for the Energy Community integration in the EU single market. Market coupling and coordinated climate action are a powerful political and economic signal for enlargement. With continued reforms, deeper integration, and shared determination, we can deliver a more secure, cleaner, and European energy future for the region.”

(Vienna, 18 December 2025)

force in January 2026, should not pose an issue for cross-border electricity trade. Full electricity market integration ahead of accession offers a clear pathway to safeguarding decarbonisation gains, supporting fair and efficient cross-border electricity exchanges, and attracting clean energy investment.

Ministers committed to advancing a coherent and predictable framework to sustain electricity market integration while creating the enabling conditions for the clean energy transition. In this context, Contracting Parties will individually pursue national carbon pricing models according to their domestic circumstances, while activities to explore coordination possibilities and ensure coherence between national carbon pricing systems in view of their gradual alignment with the *European Union Emissions Trading System* (EU ETS) continue.

Furthermore, the Energy Community framework will further incorporate core EU legislation on nature conservation, biodiversity and water protection, strengthening environmental safeguards and providing greater legal certainty for sustainable investment. To keep momentum behind the rapid growth of renewables, the Energy Community Contracting Parties will step up efforts to secure mutual recognition of Guarantees of Origin with the EU, enabling fully integrated renewable energy markets. Ministers agreed that effective coordination and implementation of the *Integrated National Energy and Climate Plans* (NECPs) is critical. The EU’s recent agreement on the 2040 climate targets sets a clear direction, and Contracting Parties must follow this pathway as they develop their long-term energy and climate policies.

It should be noted that the *Electricity Integration Package* (EIP) was completed in the Energy Community in 2022, with the obligation to transpose its content into the national legal frameworks and ensure its implementation by the end of 2023. This enables full market integration of the Contracting Parties into the single European market for electricity, based on the principle of reciprocity. This package includes nine rules –four acts which are part of the *Clean Energy for All Europeans* package:

- Directive (EU) 2019/944 on common rules for the internal market for electricity,
- Regulation (EU) 2019/943 on the internal market for electricity,
- Regulation (EU) 2019/942 establishing a European Union Agency for the Cooperation of Energy Regulators, and
- Regulation (EU) 2019/941 on risk-preparedness in the electricity sector,

and five rules and guidelines which are part of the connection network codes, the establishment of which was defined in Article 6 of Regulation (EC) No 714/2009 from the *Third Energy Package*, and which specify detailed rules on various market segments and system operation:

- Commission Regulation (EU) 2015/1222 of 24 July 2015 establishing a Guideline on Capacity Allocation and Congestion Management,
- Commission Regulation (EU) 2016/1719 of 26 September 2016 establishing a guideline on forward capacity allocation,
- Commission Regulation (EU) 2017/2195 of 23 November 2017 establishing a guideline on electricity balancing,
- Commission Regulation (EU) 2017/1485 of 2 August 2017 establishing a guideline on electricity transmission system operation, and
- Commission Regulation (EU) 2017/2196 of 24 November 2017 establishing a network code on electricity emergency and restoration.

The Energy Community Ministerial Council decision from December 2022 enabling the transposition into the *acquis* of Directive 2003/87/EC establishing a scheme for greenhouse gas emission allowance trading within the Community, Commission Implementing Regulation (EU) 2018/2066 on the monitoring and reporting of greenhouse gas emissions pursuant to Directive 2003/87/EC and Commission Implementing Regulation (EU) 2018/2067 on the verification of data and on the accreditation of verifiers pursuant to Directive 2003/87/EC, enables the Contracting Parties to have an accurate and verified overview of total emissions from energy and other installations, which forms the basis for a carbon pricing mechanism.

It is the first important step to ensure the compliance with the requirements stemming from *Regulation (EU) 2023/956 of the European Parliament and of the Council of 10 May 2023 establishing a carbon border adjustment mechanism (CBAM)*. The Regulation is part of the *Fit for 55* package, which was described in more details in the Report on Activities of the State Electricity Regulatory Commission in 2022. The *Fit for 55* package sets an intermediate target of reducing net emissions of greenhouse gases by at least 55% by 2030 compared to 1990 levels.

The significant support to the energy market development is provided by the measures adopted in the framework of the ‘Berlin Process,’ i.e. the initiative of six Western Balkans countries (WB6 initiative) which includes Albania, Bosnia and Herzegovina, Kosovo*, North Macedonia, Montenegro and Serbia. The Berlin Process is a high-level political and diplomatic initiative launched in 2014 with the aim of supporting the reform efforts of the countries in South East Europe on their European path.

The 12th Berlin Process Summit was held in London on 22 October 2025. The Summit brought together heads of states or governments from the Western Balkans and their counterparts from Austria, Bulgaria, Croatia, Germany and the United Kingdom, representatives of France, Greece, Italy, Poland and Slovenia, and high-level

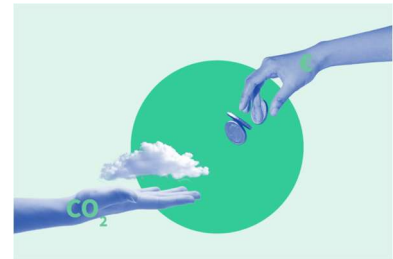

officials of the EU institutions, with the participation of the most relevant international financial institutions and organisations.

In the field of energy and climate, it was stressed that economic growth must be underpinned by the green transformation if it is to be lasting and resilient. In this spirit, participants supported the outcomes of the Second Ministerial meeting on the *Green Agenda for the Western Balkans*¹⁰ held on 14 October 2025, including the Dubrovnik Declaration, the revised Green Agenda Action Plan 2025–2030, the Climate Adaptation Roadmap and the Regional Action Plan on Plastic Pollution Prevention. These documents were recognised as essential to aligning the region with the *European Green Deal* and strengthening regional efforts towards climate change-resilient, pollution-free and resource-efficient societies, while ensuring that the transition is a just and inclusive transition for all.

Participants concluded that the green transition is an essential part of EU integration and reiterated their commitment to the full implementation of the Green Agenda. They agreed that regional economic integration and the green transition form a single, coherent agenda. Participants also acknowledged the importance of regional cooperation and international support in ensuring a just and equitable energy transition, and encouraged further investment in renewable energy, energy efficiency and green infrastructure. The leaders committed to continue implementing these initiatives with urgency and coordination, ensuring that the reached agreements deliver real benefits for citizens and businesses across the region.

The Energy Community activities in 2025 were conducted under the Presidency of Ukraine, while in 2026 Kosovo* will take over the Presidency.

The State Electricity Regulatory Commission has prepared the translation of the Energy Community *acquis*, which is presented in Annex E to this report for easy reference, and published it on its internet site (www.derk.ba).

Bosnia and Herzegovina and the Energy Community

By active participation in the Energy Community, Bosnia and Herzegovina confirms its commitment to the energy sector reforms, energy market liberalisation and harmonisation of its policies with those of EU Member States.

By signing the *Stabilisation and Association Agreement between the European Communities and their Member States, of the one part, and Bosnia and Herzegovina of the other part* (SPP), on 16 June 2008 the state took over the obligation to gradually harmonise its future and existing legislation and its proper application and implementation by

¹⁰ The Sofia Declaration on the *Green Agenda for the Western Balkans* was signed on 10 November 2020 in the context of the Berlin Process.

the end of the transitional period of six years from the day the Agreement enters into force. As the SPP entered into force on 1 June 2015, the deadline to fulfil this obligation expired on 1 June 2021.

It is obvious that additional efforts should be made at different administrative levels in Bosnia and Herzegovina to transpose and implement the Energy Community *acquis*. The deadlines for the fulfilment of all obligations have already expired.

This is also indicated by a number of the Energy Community Ministerial Council decisions on the breaches which pertain to the provisions of the Second Energy Package in the gas sector (Case ECS-8/11 S) and the transposition and implementation of the Third Energy Package (ECS-6/16 S), Directive relating to a reduction in the sulphur content of certain liquid fuels (ECS-2/13 S), Directive 2004/35/EC on environmental liability with regard to the prevention and remedying of environmental damage (ECS 10/23), as well as the non-compliance with the emission ceilings established under the National Emission Reduction Plan (ECS-9/21).

In 2024, the Energy Community Secretariat submitted to the Energy Community Ministerial Council its Reasoned Requests as part of the procedures pertaining to the failure to transpose and implement the Electricity Integration Package (ECS-6/24), Directive 2009/119/EC imposing an obligation to maintain minimum stocks of crude oil and/or petroleum product (ECS-14/24), Regulation 2017/1938 concerning measures to safeguard the security of gas supply (ECS-19/24) and Directive (EU) 2018/2001 on the promotion of the use of energy from renewable sources (ECS-14/24), thus increasing the number of pending cases for breaches of the obligations of BIH under the Treaty establishing the Energy Community to 13.

In December 2025, due to failure to transpose and implement the Electricity Integration Package (comprising nine directives and regulations mentioned above), acting upon the Reasoned Request in Case ECS-6/24, the Ministerial Council adopted a decision inviting Bosnia and Herzegovina to undertake all relevant measures to rectify the established breaches and ensure the compliance with the Energy Community *acquis* without delay, and report to the Energy Community Secretariat and Permanent High Level Group about the implementation measures taken in 2026 on a regular basis. If the breaches are not rectified by 1 July 2026 the Secretariat is invited to initiate procedures under Article 92 of the Treaty establishing the Energy Community in accordance with which serious or persistent breaches of the obligations under the Treaty may be established and, consequently, certain rights stemming from the implementation of the Treaty suspended, including the suspension of the voting rights and participation in meetings. The Ministerial Council decided in the same manner in Case ECS-19/24 pertaining to Regulation (EU) 2017/1938 concerning measures to safeguard the security of gas supply as amended by Regulation (EU) 2022/1032 with regard to gas storage.

SERC Activities in the Energy Community Bodies

The work of the State Electricity Regulatory Commission in the Energy Community was carried out with the necessary cooperation of the Ministry of Foreign Trade and Economic Relations of Bosnia and Herzegovina, through support and contribution to the implementation of different projects supporting the Energy Community development, and in particular, through proactive involvement in surveys which were planned and implemented by different groups with the wider thematic spectrum bringing together energy regulators from the region and the European Union.



SERC activities in the Energy Community continue to focus on the Energy Community Regulatory Board (ECRB), which was established on 11 December 2006 in Athens. Since then SERC actively participates in its activities, presenting and representing the interests of Bosnia and Herzegovina. The SERC chairmanship of the ECRB Customers and Retail Markets Working Group contributes to the affirmation of Bosnia and Herzegovina.

In 2025, during which the Regulatory Board held four meetings, it gave a significant contribution to the creation of Energy Community policies in the field of regulatory initiatives for the electricity and gas market development. A number of documents were prepared which include, *inter alia*, the results of electricity and gas wholesale and retail markets monitoring, which provide a quality knowledge base for future improvements of policies and acceleration of decarbonisation and market integration.

In the past year, the ECRB continued the joint activities with the Agency for the Cooperation of Energy Regulators (ACER), the Council of European Energy Regulators (CEER) and the Mediterranean Energy Regulators (MEDREG). The Regulatory Board organises a considerable part of its activities through several working groups (Customers and Retail Markets Working Group, Electricity Working Group, Gas Working Group and Working Group on Integrity and Transparency of the Wholesale Energy Market – REMIT), with the support of the ECRB Unit of the Secretariat.

4.2 Energy Regulators Regional Association – ERRA



The Energy Regulators Regional Association (ERRA) is an organisation composed of independent energy regulatory bodies from Europe, Asia, Africa and America. ERRA has 36 full members and 12 associate members and brings together the regulatory authorities from 44 countries and two regional regulatory institutions from almost all continents – Europe, Asia, Africa, North and South America (Figure 20).

The State Electricity Regulatory Commission is a full ERRA member as of 19 May 2004. In May 2010, the two Entity Regulatory Commissions from Bosnia and Herzegovina – the Regulatory Commission for

Figure 20. ERRA membership



Energy in the Federation of BIH and the Regulatory Commission for Energy of Republika Srpska, became ERRA associate members.

The goals of ERRA are the improvement of regulation of energy activities, facilitating the development of independent and stable energy regulators, cooperation among regulators, exchange of information, research and experience among the members and better access to information on world-wide experience on regulation of energy activities. ERRA also promotes and organises training courses in the field of energy regulation.

The 25th anniversary of the Energy Regulators Regional Association was marked on 11 December 2025, on the same date when the first ERRA Statute was adopted in Bucharest, Romania in the year 2000. Over the past quarter of a century, ERRA has played a key role in shaping and advancing energy regulation in Europe and beyond, building strong partnerships among a growing member base and fostering best regulatory practices.

The most current topics in the sector from the field of work of regulatory authorities were discussed during 2025 including regulatory evaluation of grid investment plans and regulatory incentives for their implementation, energy transition, incentivising renewable heating and cooling, energy storage, e-mobility, tariff policy development in the gas sector and consumer protection.

In line with their competences, SERC representatives actively participate in the activities of the ERRA General Assembly, the Electricity Markets and Economic Regulation Committee, the Renewable Energy Committee and the Customer Protection Committee. SERC fulfils its role as an ERRA member by providing relevant information on the BIH power sector and regulatory practice.

4.3 Mediterranean Energy Regulators – MEDREG



The Association of Mediterranean Energy Regulators (MEDREG) was established in 2007 in order to facilitate cooperation among the energy regulators from the countries of Northern, Southern and Eastern shores of the Mediterranean basin. The Association gathers regulatory authorities from Albania, Algeria, Bosnia and Herzegovina, Croatia, Cyprus, Egypt, France, Greece, Italy, Israel, Jordan, Lebanon, Libya, Malta, Montenegro, Morocco, North Macedonia, Palestine, Portugal, Slovenia, Spain, Tunisia and Türkiye (Figure 21).

The main objective of the Association is the promotion of clear, stable and harmonised legal and regulatory frameworks with the aim of facilitating investments in energy infrastructures and supporting market integration. Towards this goal, MEDREG promotes a permanent exchange of know-how, data collection and diffusion of expertise through comprehensive studies, recommendation reports and specialised training sessions in the field of energy regulation. The Association is also dedicated to consumer protection focusing on access to information and awareness-raising regarding changes in the sector.

Its organisation is structured around the General Assembly, the Secretariat seated in Milan and the working groups on: institutional issues, electricity, gas, environment, customer issues and renewable energy sources and energy efficiency.

SERC representatives contribute to the affirmation of BIH in MEDREG by direct participation in the work of the General Assembly and co-chairing the Consumers Working Group as well as by the provision of required information during the development of various documents.

In 2025, the focus of MEDREG activities was adequacy mechanism's role in the improvement of the electricity system, dynamic

Figure 21. Geographic scope of MEDREG



energy price regulation, green electricity trading, technical and non-technical losses in energy networks, the regulatory framework for hydrogen, energy storage developments and the protection of vulnerable consumers.

4.4 Balkan Energy School – BES

On 16 December 2022, at the initiative of the Italian Regulatory Authority for Energy, Networks and Environment (ARERA), the energy regulatory authorities of Albania, Bosnia and Herzegovina, Italy, Monte Negro and North Macedonia established the *Balkan Energy School* (BES). In the past period, the regulatory authorities of Greece and Kosovo* also became full members of BES while the regulatory authority of Serbia holds observer status. The Balkan Energy School, which is seated in Milan, Italy, will promote the harmonisation of the regulatory framework at the regional level to support the development of the Balkan energy market and its effective integration at EU level. Its activities will be focused on the development of electricity and gas networks, RES integration, market coupling, and other relevant activities, under the umbrella of energy transition and through an intense activity of capacity building and know-how exchange. The Balkan Energy School was born from the successful experience of the *Know How Exchange Program* (KEP), that is, *Support for Strengthening Energy Regulatory Authorities in the Western Balkans*, which was promoted and coordinated by ARERA as part of the funding program of the Central European Initiative (CEI).

In 2025, two meetings of the General Assembly of the Balkan Energy School were held and five educational workshops were successfully organised dedicated to the latest energy related topics in the region.

4.5 Council of European Energy Regulators – CEER

The Council of European Energy Regulators (CEER) is a non-profitable association of independent statutory bodies responsible for energy regulation at national level. CEER brings together 38 national regulatory authorities (29 full members and nine observers) from European Union Member States, European Free Trade Association (EFTA) and EU accession countries (Figure 22).

The overall aim of CEER is to facilitate the creation of a single, competitive, efficient and sustainable market for gas and electricity in Europe. The Council of European Energy Regulators acts as a platform for cooperation, information exchange and assistance between Europe's national energy regulators in the energy sector.

The State Electricity Regulatory Commission has observer status in CEER as of 1 January 2017. As Observers, SERC staff participates in activities of the CEER General Assembly and CEER working groups.

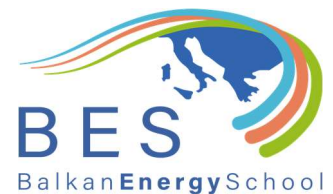

Figure 22. CEER membership



SERC has access to the CEER’s established regulatory network and cooperation tools, and the possibility of a deep understanding of European Union energy policies and practices. In this regard, participation in activities of the Council of European Energy Regulators is also helpful on the path of Bosnia and Herzegovina towards EU membership, and the full obligations this will entail in terms of implementation of the *acquis* in the field of energy.

A large part of the CEER activities in 2025 was dedicated to well-functioning retail markets and the protection of customers and their empowerment in order to enable them to engage more effectively in the market and the development of rules.

4.6 International Confederation of Energy Regulators – ICER



The International Confederation of Energy Regulators (ICER), established in October 2009, is a voluntary framework for cooperation between energy regulators from around the globe. ICER’s aim is to improve public and policy-maker awareness and understanding of energy regulation and its role in addressing a wide spectrum of socio-economic, environmental and market issues. Over 270 regulatory authorities are included in the ICER’s membership through 15 regional regulatory associations (Figure 23).

SERC participates in and follows the activities of ICER through ERA, MEDREG and CEER, and provides support to ICER’s activities in different ways, including the exchange of knowledge

Figure 23. ICER members

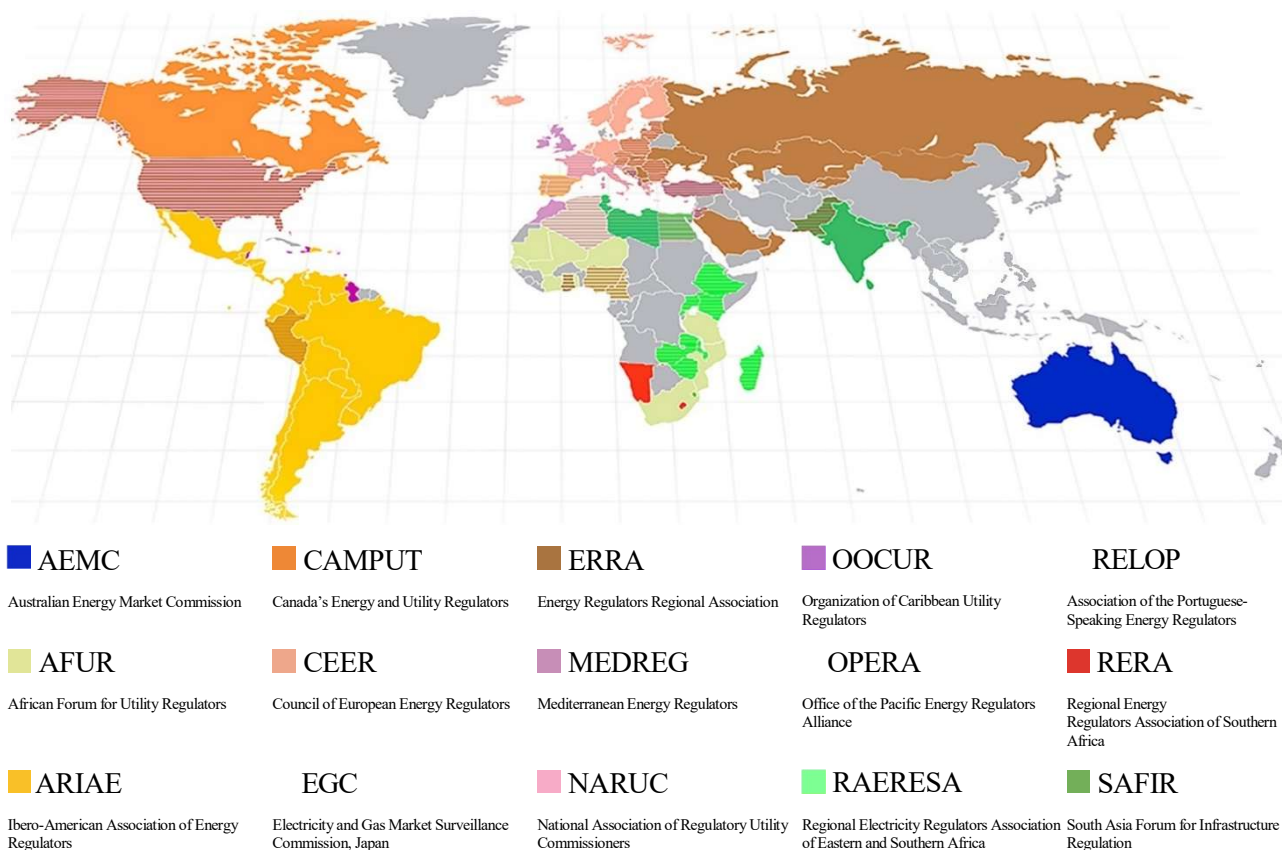

and the provision of required information, thus enabling an insight into and the exchange of practice in the area of relevance to regulatory activities.

ICER promoted the advancement of women in energy by streamlining gender perspective in all of its activities, which is the continuation of activities launched in October 2013 in ICER's *Women in Energy* initiative. In the same year, ICER launched its *Chronicle* as a means to further promote exchange of regulatory expertise and research.

ICER's work is focused around several key areas, in line with the topics defined during each *World Forum on Energy Regulation*, which is held once every three years. The Eighth World Forum on Energy Regulation was held from 22 to 25 August 2023 in Lima, Peru. The main theme of this forum was the energy transformation challenge with focus on competitiveness, institutional framework, universal access to energy and energy transition.

The Ninth World Forum on Energy Regulation will be held from 21 to 25 September 2026 in Tbilisi, Georgia. On that occasion, the key players in the global energy industry, including regulators, policy makers, industry leaders and academics will exchange opinions of the strategic regulatory frameworks and best practices. The event will focus on the latest issues related to energy markets, sustainability and regulatory cooperation.



5. AUDIT REPORT

Pursuant to the *Law on Transmission of Electric Power, Regulator and System Operator of Bosnia and Herzegovina*, the State Electricity Regulatory Commission is funded from its own revenues. The basic revenue in 2025 was the regulatory fee, which was paid by the holders of licences for performance of the activity of electricity transmission, independent system operator, international electricity trading and supply of customers with electricity and electricity distribution in the Brčko District of BIH. The regulatory fee is determined so as to cover SERC's costs, while the obligations to pay the regulatory fee in the forthcoming period are reduced by an excess of revenues over expenditures. SERC passed the *Decision determining the regulatory fee for 2025* on 10 September 2024, thus enabling the licence holders to plan their financial obligations in a timely manner.

In addition to efforts to attain the mentioned own funding, SERC financial dealings also include the following activities:

- incurrence and settlement of financial obligations for the needs defined in the approved Financial Plan,
- short-term planning and cash flow management,
- regular monitoring of the Financial Plan implementation in the current year,
- an analysis and estimate of future cash flows for the purpose of developing a new financial plan,
- preparation of the financial plan for the following year,
- monitoring and development of financial management and internal control,
- internal financial reporting as the basis for adoption of the relevant business decisions, and
- financial reporting to external bodies, authorised institutions and the public.

The final outcome of the aforementioned activities and adopted decisions are financial reports presenting business results at the end of a business year. SERC financial reports are audited on an annual basis in order to have an independent and impartial audit of the stated business results as well as to check the compliance of these procedures with the applicable regulations.

The audit of SERC financial reports for the previous year was performed in the first quarter of 2025 by the Auditing, Accounting and Consulting Company Revik d.o.o., Sarajevo, a member of *HLB International*, a network of independent companies providing professional services of auditing, accounting and business consulting.

While performing an audit pursuant to the International Standards on Auditing, the auditors collected evidence on transactions and

“In our opinion, the enclosed annual financial reports show realistically and objectively the financial standing of SERC on 31 December 2024, its financial performance and cash flow for the year which ended at that point, in accordance with the Law on Accounting and Auditing of the Federation of BIH and the International Financial Reporting Standards (IFRS).”

Revik d.o.o.,
Sarajevo, 17 March 2025

Revik d.o.o. Sarajevo

Member of **HLB** International

other data published in the financial reports to be confident beyond reasonable doubt that they did not include any relevant material errors. In addition to determining the objectivity of the financial reports as a whole, the audit included the evaluation of accounting policies applied and relevant estimates made by the SERC management.

Based on the collected data, the independent auditor gave a positive assessment of SERC financial reports for 2024. It is the opinion of the independent auditor that the presentation of financial reports, recognising and measuring of transactions and business events, objectively and realistically present the state of assets, liabilities, capital and financial results of business performance.

With the mentioned opinion, SERC maintained the highest audit opinion for compliance of its financial reports with the applicable international accounting standards and legal regulations, which SERC was given by external auditors since its establishment, including the opinions by the Audit Office of the Institutions of Bosnia and Herzegovina.

Through external auditing, SERC ensures an independent and reliable report on the use of property and management of revenues and expenditures. Lead by the commitment to the principles of objectivity and transparency in its work, with the aim of providing information on its financial standing and business results, the State Regulatory Commission publishes its audit report on an annual basis. In addition to the publication in the legally prescribed register and the Official Gazette of BIH, number 28/25, the audited financial reports for 2024 were also published on the SERC website.

SERC established the internal audit function through the Internal Audit Agreement signed with the Internal Audit Unit (JIR) of the Ministry of Foreign Trade and Economic Relations of BIH. For the purpose of preparing an Internal Audit Strategic Work Plan for the Period 2025 – 2027 and an Internal Audit Annual Work Plan for 2025, an updated Risk Register was submitted to JIR in a timely manner. In accordance with the risk assessment, the relevant Internal Audit Unit neither planned nor performed the internal audit procedure in SERC.

In accordance with the provisions of the *Law on Transmission of Electric Power, Regulator and System Operator of Bosnia and Herzegovina*, SERC adopted the Financial Plan for 2026, which was published in the Official Gazette of BIH, number 56/25 and submitted to the Parliamentary Assembly of Bosnia and Herzegovina. On the basis of the adopted plan, the *Decision determining the regulatory fee for 2026* was adopted on 17 September 2025, enabling the licence holders to plan their activities in 2026 in a timely manner.



6. MAIN ACTIVITIES IN 2026

The State Electricity Regulatory Commission will continue its activities on ensuring the conditions for free trade and unhindered electricity supply in accordance with the predefined quality standard to the benefit of citizens of Bosnia and Herzegovina, and in compliance with international agreements, national laws, the relevant European regulations and directives as well as other internal electricity market rules.

In 2026 SERC will maintain continuous cooperation with the Parliamentary Assembly of Bosnia and Herzegovina (PABIH), in particular with the Committee on Traffic and Communications of the House of Representatives of PABIH and the Committee on Foreign and Trade Policy, Customs, Traffic and Communications of the House of Peoples of PABIH. In addition, the focus of interest will remain on the information exchange and harmonisation of key regulatory activities with the Ministry of Foreign Trade and Economic Relation of BIH, which is competent for policy creation in accordance with the *Law on Transmission of Electric Power, Regulator and System Operator of Bosnia and Herzegovina*.

All existing modalities of mutual follow up and harmonisation of activities will be used also in 2026 in relationships with the Regulatory Commission for Energy in the Federation of Bosnia and Herzegovina and the Regulatory Commission for Energy of Republika Srpska as well as with other regulatory bodies established at national level, primarily the Competition Council of Bosnia and Herzegovina.

In order to meet the need of different decision-making levels for quality and reliable statistical energy data, SERC will remain a reference source and an active generator of these data. To this end, SERC will follow up on the developments of EU rules and comply with the Energy Community agenda continuing its cooperation with the Agency for Statistics of Bosnia and Herzegovina.

Furthermore, SERC will follow activities and trends in the whole energy sector and directly participate in all relevant events.

Through its activities SERC will focus on:

- Setting tariffs in line with SERC competencies,
- Issuance, modification, suspension and revocation of licences,
- Regulatory monitoring of licensed entities,
- Creation of new regulatory rules and analysis of the regulatory rules already adopted and the existing practice, together with review and revision of SERC acts,
- Monitoring the procurement of ancillary service and provision of the system services and balancing of the BIH power system, and, on a needs basis, continuing the development of a design for these services,

- Increasing the level of the electricity market integration,
- Contribution to organising and functioning of the wholesale market, including the establishment of an institutional framework for an organised day-ahead and intraday market,
- Contribution to organising and functioning of the fully open retail market in BIH,
- Development of rules regulating connection of users to the transmission system,
- Capacity building in terms of the fulfilment of international obligations with regard to regulatory reporting,
- Approving and monitoring the implementation of rules developed by the Independent System Operator in Bosnia and Herzegovina, Elektroprenos BIH and Komunalno Brčko,
- Approving the *Indicative Generation Development Plan for the Period 2026 – 2035* and the *Long-Term Transmission Network Development Plan* for the upcoming ten-year period as well as an *Investment Plan of Elektroprenos BIH*,
- Monitoring the implementation of the Inter-TSO Compensation Mechanism (ITC mechanism) and operation of the Coordinated Auction Office in South East Europe (SEE CAO),
- Regulatory activities regarding the network codes and guidelines and the Regulation on wholesale energy market integrity and transparency,
- Regulatory activities regarding the improvement of cybersecurity in the BIH power sector,
- Sharing information on regulatory practice with the regulated entities and the public, and
- Performing tasks entrusted to SERC, especially taking into account the content of the *Draft Law on the Regulator, Transmission and Electricity Market in Bosnia and Herzegovina*, which at the time of preparing this report was in the process of being adopted by the Parliamentary Assembly of Bosnia and Herzegovina.

While conducting its activities SERC will take into account the protection of customers and give its full contribution to the creation of best applicable solutions in accordance with competences vested in SERC under law.

Taking into account the fact that under the Treaty establishing the Energy Community Bosnia and Herzegovina is obligated to transpose the rules of the European Union on the internal energy market (Third Energy Package) into its national legislation and apply them in practice, SERC will contribute to the legal framework development in line with its competences and through optimal coordination with other stakeholders.

The State Electricity Regulatory Commission will take the same approach regarding the extension of the *acquis*, that is, legal framework of the Energy Community, which from 15 December 2022 includes the whole package of European Union energy rules the goal of which is to provide competition needed to facilitate the clean energy transition (*Clean Energy for All Europeans*) as well as all network codes, thus, with the required adaptations and adoption of the *Procedural Act on Regional Market Integration*, completing the Electricity Integration Package (EIP) in the Energy Community.

The implementation of the energy transition and the power sector reform in Bosnia and Herzegovina, harmonisation of secondary legislation and efficient coordination among the bodies participating in its drafting and development is in the interest of all stakeholders. The aim is to create a clear and stable legal framework based on the EU directives and regulations on the internal electricity market.

In this context, SERC is planning to continue to actively participate in the development of an EU-*acquis*-compliant legislative framework in the field of electricity in Bosnia and Herzegovina as well as the implementation and application of the new law after its adoption, and in removal of shortcomings in the electricity sector as specified in the reports of the European Commission on BIH.

In line with its competences, the State Regulatory Commission will contribute to the implementation of *Bosnia and Herzegovina's Reform Agenda* (Reform Program of Bosnia and Herzegovina¹¹), as well as the implementation of recommendations of meetings of the BIH Stabilisation and Association Committee and Subcommittee on Transport, Energy, Environment and Regional Development. In the same manner, SERC will support the development of an *Integrated National Energy and Climate Plan of Bosnia and Herzegovina* and, upon its adoption, the implementation thereof.

SERC will participate in supporting and implementing regional priorities and Energy Community projects as well as the priorities identified for the BIH power sector within the Energy Community as specified in the Conclusions of the BIH Council and the *Annual Implementation Report of the Energy Community*. SERC will fully contribute to the implementation of measures in the energy sector as agreed within the 'Berlin Process.'

In 2026, the multiannual project of the United States Government – *Energy Policy Activity* (EPA), launched on 1 October 2024, will continue. SERC will follow up its activities and participate in the

¹¹ The Council of Ministers of BIH adopted the document on 30 September 2025 in order to receive the financial support within the framework of the *Reform and Growth Facility for the Western Balkans*. On 28 November 2025, the European Commission adopted the Decision approving the BIH Reform Agenda and published it on 3 December 2025.

implementation of some components which are of relevance for the regulatory activities.

SERC will continue to cooperate with the German Agency for International Cooperation (*Deutsche Gesellschaft für Internationale Zusammenarbeit – GIZ*) and actively participate in the project titled *Community Action for Energy Transition in Bosnia and Herzegovina*, which was launched in June 2023 as well as in the second phase of the regional project *Green Agenda: Decarbonisation of the Electricity Sector in the Western Balkans*.

The activities of international bodies pertaining to the electricity market regulation will also be the centre of attention, primarily of those in the work of which SERC participates:

- ECRB – the Energy Community Regulatory Board,
- ERRA – the Energy Regulators Regional Association,
- MEDREG – the Mediterranean Energy Regulators,
- BES – the Balkan Energy School,
- CEER – the Council of European Energy Regulators,
- ICER – the International Confederation of Energy Regulators.

The State Regulatory Commission will continue to follow up the work of the Agency for the Cooperation of Energy Regulators (ACER), and depending on the legal framework development in Bosnia and Herzegovina consider the possibility to directly participate in activities of this body.

In the forthcoming period SERC will analyse the contents and activities stemming from the new rules which are developed by the European Union institutions. This includes the *European Grids Package*, which was proposed by the European Commission on 10 December 2025 aimed at full interconnection of the energy system, enabling free and safe flow of clean and affordable domestic energy, as well as the *Citizens Energy Package*, which the European Commission plans to propose in the first quarter of 2026 with the aim of protecting and empowering consumers in the just transition.

This approach takes into account the fact that all new EU regulations and directives in the energy sector become binding also for Bosnia and Herzegovina through the mechanisms developed under the Treaty establishing the Energy Community.

ANNEX A: Basic Data on the Electric Power System of Bosnia and Herzegovina

(Source: NOS BIH, Elektroprenos BIH and public electric power utilities in BIH)

Basic Data on Installed Capacity of Generating Units

Total installed capacity of generating facilities in Bosnia and Herzegovina amounts to 5,547.42 MW, with 2,128.02 MW, 1,965 MW, 272.4 MW and 305.59 MW installed in the major hydropower plants, thermal power plants, larger wind power plants and larger photovoltaic (solar) power plants respectively. Installed capacity of small hydropower plants, small solar power plants, biogas and biomass power plants and small wind power plants amounts to 171.27 MW, 608.80 MW, 3.39 MW and 0.10 MW respectively, while installed capacity of industrial powers plants amounts to 92.85 MW.

Major Generating Units

Hydropower plants	Capacity of power unit (MW)	Total installed capacity (MW)
Bočac	2×55	110
Čapljina	2×210	420
Dub	2×4.7	9.4
Dubrovnik (BA+HR)	126+108	234
Grabovica	2×57	114
Jablanica	6×30	180
Jajce I	2×30	60
Jajce II	3×10	30
Mostar	3×24	72
Mostarsko blato	2×30	60
Peć-Mlini	2×15.3	30.6
Rama	80+90	170
Salakovac	3×70	210
Trebinje I	2×54+63	171
Trebinje II	8	8
Ulog	2×17.56	35.12
Ustiprača	2×3.45	6.9
Višegrad	3×105	315

Wind power plants	Capacity of power unit (MW)	Total installed capacity (MW)
Ivan Sedlo	5×5	25
Ivovik	20×4.2	84
Jelovača	18×2	36
Mesihovina	22×2.3	50.6
Oštrc	6×4.8	28.8
Podveležje	15×3.2	48

Photovoltaic power plants		Installed capacity (MW)
Bileća		55
Brottnjo 1 and 2		9.98
Deling Invest		29.75
Eco-Wat (I+II+III)	57+35,47+12	104,47
Petnjik		29.9
Plavo sunce 55 – 59		20
Plavo sunce 2, 3, 52 – 54		20
Polog		7.99
Zvizdan		28.5

Thermal power plants	Installed capacity (MW)	Available capacity (MW)
GACKO	300	276
KAKANJ	450	398
<i>Kakanj G5</i>	<i>110</i>	<i>100</i>
<i>Kakanj G6</i>	<i>110</i>	<i>90</i>
<i>Kakanj G7</i>	<i>230</i>	<i>208</i>
STANARI	300	283
TUZLA	615	550
<i>Tuzla G4</i>	<i>200</i>	<i>182</i>
<i>Tuzla G5</i>	<i>200</i>	<i>180</i>
<i>Tuzla G6</i>	<i>215</i>	<i>188</i>
UGLJEVIK	300	279

Basic Data on the Transmission System

<i>Transmission lines</i>	
Nominal voltage of transmission lines	Length (km)
400 kV	865.97
220 kV	1,526.23
110 kV	4,093.95
110 kV – cable line	34.68

<i>Interconnections</i>	
Nominal voltage of transmission lines	Number of interconnectors
400 kV	4
220 kV	10
110 kV	23
<i>Total</i>	<i>37</i>

<i>Substations</i>		
Type of substation	Number of substations	Installed capacity (MVA)
TS 400/x kV	10	6,130.5
TS 220/x kV	8	1,423.0
TS 110/x kV	137	5,889.0

<i>Transformers</i>		
Transmission ratio of transformers	Number of transformers	Installed capacity (MVA)
TR 400/x kV	14	4,900.0
TR 220/x kV	14	2,100.0
TR 110/x kV	260	6,431.0

ANNEX C: Balance Values of the Electric Power Sector of Bosnia and Herzegovina

(GWh)

Year 2025	EP BIH	ERS	EP HZHB	Komunalno Brčko	Other entities	BIH
Generation in hydropower plants	1,121.23	1,846.03	1,362.81		102.52	4,432.59
Generation in thermal power plants	3,510.89	2,440.76			1,982.27	7,933.92
Generation in larger solar and wind PPs	118.79		151.17		852.64	1,122.60
Generation in small and industrial PPs	57.70	48.64			944.73	1,051.07
Generation	4,808.61	4,335.43	1,513.98		3,882.16	14,540.18
Customers connected to distr. network	5,370.80	4,035.04	1,558.50	287.82		11,252.16
Transmission losses						350.02
Large customers	481.26	149.51	19.36			650.13
PPs self-consumption and pumping	1.87	15.32	52.32		8.58	78.09
Consumption	5,853.93	4,199.87	1,630.18	287.82	8.58	12,330.40
Year 2024	EP BIH	ERS	EP HZHB	Komunalno Brčko	Other entities	BIH
Generation in hydropower plants	1,198.43	2,028.50	1,448.89		56.12	4,731.94
Generation in thermal power plants	3,954.04	2,603.22			1,926.20	8,483.46
Generation in larger solar and wind PPs	105.60		138.57		357.39	601.56
Generation in small and industrial PPs	59.59	37.61			639.43	736.63
Generation	5,317.66	4,669.33	1,587.46		2,979.14	14,553.59
Customers connected to distr. network	5,206.13	3,911.86	1,496.67	288.18		10,902.84
Transmission losses						328.46
Large customers	506.29	338.41	15.34			860.04
PPs self-consumption and pumping	1.01	16.20	13.66		9.21	40.08
Consumption	5,713.43	4,266.47	1,525.67	288.18	9.21	12,131.42
Year 2023	EP BIH	ERS	EP HZHB	Komunalno Brčko	Other entities	BIH
Generation in hydropower plants	1,565.65	2,693.75	1,931.30		93.14	6,283.84
Generation in thermal power plants	3,593.97	2,823.91			1,987.36	8,405.24
Generation in larger solar and wind PPs	100.21		151.12		119.20	370.53
Generation in small and industrial PPs	73.63	67.96			620.50	762.09
Generation	5,333.46	5,585.62	2,082.42		2,820.20	15,821.70
Customers connected to distr. network	5,024.59	3,805.03	1,440.27	277.84		10,547.73
Transmission losses						334.02
Large customers	503.82	188.83	24.97			717.62
PPs self-consumption and pumping	0.34	13.42	15.01		6.49	35.26
Consumption	5,528.75	4,007.28	1,480.25	277.84	6.49	11,634.63
Year 2022	EP BIH	ERS	EP HZHB	Komunalno Brčko	Other entities	BIH
Generation in hydropower plants	1,125.62	1,978.29	1,296.81		57.83	4,458.55
Generation in thermal power plants	4,544.09	2,957.13			2,128.21	9,629.43
Generation in larger solar and wind PPs	121.16		154.64		114.59	390.39
Generation in small and industrial PPs	58.33	40.53			458.73	557.59
Generation	5,849.20	4,975.95	1,451.45		2,759.36	15,035.96
Customers connected to distr. network	4,911.88	3,917.49	1,431.65	284.85		10,545.87
Transmission losses						333.03
Large customers	511.51	573.76	38.97			1,124.24
PPs self-consumption and pumping		14.68	35.03		4.79	54.50
Consumption	5,423.39	4,505.93	1,505.65	284.85	4.79	12,057.64
Year 2021	EP BIH	ERS	EP HZHB	Komunalno Brčko	Other entities	BIH
Generation in hydropower plants	1,665.49	2,487.46	2,082.77		78.27	6,313.99
Generation in thermal power plants	4,840.82	3,107.68			1,872.48	9,820.98
Generation in larger solar and wind PPs	107.17		162.99		111.65	381.81
Generation in small and industrial PPs	63.59	58.89			416.17	538.66
Generation	6,677.06	5,654.04	2,245.76		2,478.58	17,055.44
Customers connected to distr. network	4,861.66	3,896.14	1,424.27	285.65		10,467.72
Transmission losses						369.20
Large customers	549.67	422.94	12.95		184.32	1,169.88
PPs self-consumption and pumping		12.43	143.86		6.69	162.98
Consumption	5,411.33	4,331.51	1,581.08	285.65	191.01	12,169.78

ANNEX D: Electric Power Indicators of Bosnia and Herzegovina

		2021	2022	2023	2024	2025
Electricity generation	(GWh)	17,055.44	15,035.96	15,821.70	14,553.59	14,540.18
Net imports	(GWh)	3,312.00	3,875.64	3,699.33	4,753.14	4,641.03
Net exports	(GWh)	8,197.66	6,853.90	7,886.41	7,175.32	6,850.81
Total electricity supplied	(GWh)	12,169.78	12,057.64	11,634.63	12,131.42	12,330.40
Gross electricity consumption	(GWh)	12,169.78	12,057.64	11,634.63	12,131.42	12,330.40
Transmission losses	(GWh)	369.20	333.03	334.02	328.46	350.02
Transmission losses	(%)	1.87%	1.83%	1.79%	1.78%	1.93%
Distribution losses	(GWh)	965.04	931.12	909.69	934.80	914.58
Distribution losses	(%)	9.22%	8.83%	8.62%	8.57%	8.13%
PPs self-consumption and pumping	(GWh)	162.98	54.50	35.26	40.07	78.09
Total final consumption	(GWh)	10,672.56	10,738.99	10,355.65	10,828.09	10,987.71
	<i>Non-households</i>	5,761.04	5,810.40	5,355.32	5,586.56	5,486.92
	<i>Households</i>	4,911.52	4,928.59	5,000.33	5,241.53	5,500.79
Maximum system load	(MW)	1,909.00	1,893.00	1,851.00	2,049.00	2,209.00
Net maximum capacity of power plants	(MW)	4,608.26	4,655.62	4,770.23	5,185.14	5,547.42
Coal-fired power plants		2,157.85	2,157.85	2,157.85	2,057.85	2,057.85
Hydropower plants in total		2,256.78	2,258.49	2,262.48	2,297.60	2,299.29
	<i>small hydropower plants</i>	180.18	181.89	185.88	168.54	171.27
	<i>pumped storage power plants</i>	420.00	420.00	420.00	420.00	420.00
Total of other renewable sources		193.62	239.27	349.90	829.35	1,190.28
	<i>wind</i>	135.00	135.00	135.00	219.00	272.50
	<i>solar</i>	56.51	101.56	212.19	607.64	914.39
	<i>biomass</i>	1.12	1.12	1.12	1.12	1.12
	<i>biogas</i>	0.99	1.59	1.59	1.59	2.27
Transmission network	(km)	6,457.78	6,458.78	6,460.12	6,516.02	6,520.83
	<i>400 kV</i>	865.93	865.93	865.97	865.97	865.97
	<i>220 kV</i>	1,520.09	1,520.09	1,520.81	1,526.23	1,526.23
	<i>110 kV</i>	4,071.74	4,072.74	4,073.34	4,089.16	4,128.63
Number of interconnectors		37	37	37	37	37
Installed substation capacity	(MVA)	13,065.50	13,065.50	13,342.50	13,442.50	13,431.00
Electricity customers		1,570,415	1,590,197	1,607,251	1,618,585	1,623,815
	<i>Non-households</i>	125,895	128,354	130,649	131,571	133,086
	<i>Households</i>	1,444,520	1,461,843	1,476,602	1,487,014	1,490,729
Eligible customers		1,570,415	1,590,197	1,607,251	1,618,585	1,623,815
Customers that switched supplier		12	7	4	4	3
Electricity supplied	(GWh)	235.55	251.34	22.90	14.96	18.00
Share in final consumption	(%)	2.21%	2.34%	0.22%	0.15%	0.16%
Customers for whom prices are not regulated		9,910	13,442	14,723	39,412	41,175
Electricity supplied	(GWh)	3,851.16	4,234.31	3,834.69	4,353.63	4,836.44
Share in final consumption	(%)	36.08%	39.43%	37.03%	40.21%	44.02%

ANNEX E: Energy Community *Acquis*

The Energy Community *acquis* (Energy Community legal framework) follows the development of the European Union legal framework, the so-called *acquis communautaire*, in the area pertaining to electricity and related sectors. When defining the new *acquis*, the Ministerial Council (MC) and the Permanent High-Level Group (PHLG) make some adaptations of the EU rules to the Energy Community institutional framework, taking into account the time limits in the region. This approach ensures that the Contracting Parties keep up with the development of the European Union and regularly harmonise their legal framework with the one in the EU.

The Energy Community *acquis* includes the key energy legislation of the EU in the fields of electricity, gas, security of supply, oil, environment, renewable energy sources, energy efficiency, infrastructure, competition and statistics. In November 2021, the first part of the *Clean Energy for All Europeans* package was included in the Energy Community *acquis* while the remainder of the Package was included in December 2022, thus completing the *Energy Integration Package*. Regulation (EU) 2022/869 on guidelines for trans-European energy infrastructure and Commission Implementing Regulation (EU) 2022/2299 were included in December 2023 and December 2024 respectively.

Note: The general deadlines for transposition of the rules into national legislation and their implementation are provided in the brackets.

Cross-Cutting Acquis

- Regulation (EU) 2018/1999 of the European Parliament and of the Council of 11 December 2018 on the Governance of the Energy Union and Climate Action, amending Regulations (EC) No 663/2009 and (EC) No 715/2009 of the European Parliament and of the Council, Directives 94/22/EC, 98/70/EC, 2009/31/EC, 2009/73/EC, 2010/31/EU, 2012/27/EU and 2013/30/EU of the European Parliament and of the Council, Council Directives 2009/119/EC and (EU) 2015/652 and repealing Regulation (EU) No 525/2013 of the European Parliament and of the Council, as adapted by Decision 2021/14/MC-EnC (deadline: 31 December 2022),
- Commission Delegated Regulation (EU) 2020/1044 of 8 May 2020 supplementing Regulation (EU) 2018/1999 of the European Parliament and of the Council with regard to values for global warming potentials and the inventory guidelines and with regard to the Union inventory system and repealing Commission Delegated Regulation (EU) No 666/2014, as adapted by Decision 2021/14/MC-EnC (deadline: 31 December 2022),
- Commission Implementing Regulation (EU) 2020/1208 of 7 August 2020 on structure, format, submission processes and review of information reported by Member States pursuant to Regulation (EU) 2018/1999 of the European Parliament and of the Council and repealing Commission Implementing Regulation (EU) No 749/2014, as adapted by Decision 2021/14/MC-EnC (deadline: 31 December 2022),
- Commission Implementing Regulation (EU) 2022/2299 of 15 November 2022 laying down rules for the application of Regulation (EU) 2018/1999 of the European Parliament and of the Council as regards the structure, format, technical details and process for the integrated national energy and climate progress reports, as adapted by Decision 2024/01/PHLG-EnC (deadline: 15 March 2025),
- Regulation (EU) No 1227/2011 of the European Parliament and of the Council of 25 October 2011 on wholesale energy market integrity and transparency, as adapted by Decision 2018/10/MC-EnC (deadline: 29 May 2020).

Acquis on electricity

- Directive (EU) 2019/944 of the European Parliament and of the Council of 5 June 2019 on common rules for the internal market for electricity and amending Directive 2012/27/EU (recast), as adapted by Decision 2021/13/MC-EnC (deadline: 31 December 2023),
- Regulation (EU) 2019/943 of the European Parliament and of the Council of 5 June 2019 on the internal market for electricity, as adapted by Decision 2022/03/MC-EnC (deadline: 31 December 2023),
- Regulation (EU) 2019/942 of the European Parliament and of the Council of 5 June 2019 establishing a European Union Agency for the Cooperation of Energy Regulators, as adapted by Decision 2022/03/MC-EnC (deadline: 31 December 2023),
- Commission Regulation (EU) 2017/2196 of 24 November 2017 establishing a network code on electricity emergency and restoration, as adapted by Decision 2022/03/MC-EnC (deadline: 31 December 2023),
- Commission Regulation (EU) 2017/2195 of 23 November 2017 establishing a guideline on electricity balancing, as adapted by Decision 2022/03/MC-EnC (deadline: 31 December 2023),
- Commission Regulation (EU) 2017/1485 of 2 August 2017 establishing a guideline on electricity transmission system operation, as adapted by Decision 2022/03/MC-EnC (deadline: 31 December 2023),
- Commission Regulation (EU) 2016/1719 of 26 September 2016 establishing a guideline on electricity transmission system operation, as adapted by Decision 2022/03/MC-EnC (deadline: 31 December 2023),
- Commission Regulation (EU) 2016/1447 of 26 August 2016 establishing a network code on requirements for grid connection of high voltage direct current systems and direct current-connected power park modules, as adapted by Decision 2018/04/PHLG-EnC (deadline: 12 July 2021),
- Commission Regulation (EU) No 2016/1388 of 17 August 2016 establishing a network code on demand connection, as adapted by Decision 2018/05/PHLG-EnC (deadline: 12 July 2021),
- Commission Regulation (EU) No 2016/631 of 14 April 2016 establishing a network code on requirements for grid connection of generators, as adapted by Decision 2018/03/PHLG-EnC (deadline: 12 July 2021),
- Commission Regulation (EU) 2015/1222 of 24 July 2015 establishing a guideline on capacity allocation and congestion management, as adapted by Decision 2022/03/MC-EnC (deadline: 31 December 2023),
- Commission Regulation (EU) No 543/2013 of 14 June 2013 on submission and publication of data in electricity markets and amending Annex I to Regulation (EC) No 714/2009 of the European Parliament and of the Council, as adapted by Decision 2015/01/PHLG-EnC (deadline: 24 December 2015),
- Regulation (EU) No 838/2010 of the European Commission of 23 September 2010 on laying down guidelines relating to the inter-transmission system operator compensation mechanism and a common regulatory approach to transmission charging, as adapted by Decision 2013/01/PHLG-EnC (deadline: 1 January 2014).

Continued on the next page ⇨

⇒ Continuation from the previous page

Acquis on gas

- Commission Regulation (EU) No 2017/460 of 16 March 2017 establishing a network code on harmonised transmission tariff structures for gas, as adapted by Decision 2018/07/PHLG-EnC (deadline: 28 February 2020),
- Commission Regulation (EU) No 2017/459 of 16 March 2017 establishing a network code on capacity allocation mechanisms in gas transmission systems, as adapted by Decision 2018/06/PHLG-EnC (deadline: 28 February 2020),
- Commission Regulation (EU) No 2015/703 of 30 April 2015 establishing a Network Code on Interoperability and Data Exchange Rules, as adapted by Decision 2018/02/PHLG-EnC (deadline: 1 October 2018),
- Commission Regulation (EU) No 312/2014 of 26 March 2014 establishing a Network Code on Gas Balancing of Transmission Networks, as adapted by Decision 2019/01/PHLG-EnC (deadline: 12 December 2020),
- Directive 2009/73/EC of the European Parliament and of the Council of 13 July 2009 concerning common rules for the internal natural gas market and repealing Directive 2003/55/EC, as adapted by Decision 2011/02/MC-EnC (deadline: 1 January 2015),
- Regulation (EC) No 715/2009 of the European Parliament and of the Council of 13 July 2009 on conditions for access to the natural gas transmission network and repealing Regulation (EC) No 1775/2005, as adapted by Decisions 2011/02/MC-EnC, 2018/01/PHLG-EnC, 2021/14/MC-EnC and 2022/01/MC (deadline: 1 January 2015).

Acquis on security of supply

- Regulation (EU) 2019/941 of the European Parliament and of the Council of 5 June 2019 on risk-preparedness in the electricity sector and repealing Directive 2005/89/EC, as adapted by Decision 2021/13/MC-EnC (deadline: 31 December 2023),
- Regulation (EU) 2017/1938 of the European Parliament and of the Council of 25 October 2017 concerning measures to safeguard the security of gas supply and repealing Regulation (EU) No 994/2010, as adapted by Decisions 2021/15/MC-EnC, 2022/01/MC-EnC and 2025/09/MC-EnC (deadline: 31 December 2022).

Acquis on oil

- Directive 2009/119/EC of the European Parliament and of the Council of 14 September 2009 imposing an obligation on Member States to maintain minimum stocks of crude oil and/or petroleum products, as adapted by Decision 2012/03/MC-EnC (deadline: 1 January 2023).

Acquis on environment

- Commission Implementing Regulation (EU) 2018/2067 of 19 December 2018 on the verification of data and on the accreditation of verifiers pursuant to Directive 2003/87/EC of the European Parliament and of the Council, as adapted by Decision 2022/05/MC-EnC (deadline: 31 December 2023),
- Commission Implementing Regulation (EU) 2018/2066 of 19 December 2018 on the monitoring and reporting of greenhouse gas emissions pursuant to Directive 2003/87/EC of the European Parliament and of the Council and amending Commission Regulation (EU) No 601/2012, as adapted by Decision 2022/05/MC-EnC (deadline: 31 December 2023),
- Directive (EU) 2016/802 of the European Parliament and of the Council of 11 May 2016 relating to a reduction in the sulphur content of certain liquid fuels, as adapted by Decision 2016/15/MC-EnC (deadline: 30 June 2018),
- Directive 2011/92/EU of the European Parliament and of the Council of 13 December 2011 on the assessment of the effects of certain public and private projects on the environment as amended by Directive 2014/52/EU, as adapted by Decision 2016/12/MC-EnC (deadline: 1 January 2019),
- Directive 2010/75/EU of the European Parliament and of the Council of 24 November 2010 on industrial emissions (integrated pollution prevention and control), as adapted by Decisions 2013/06/MC-EnC and 2015/06/MC-EnC (deadline: 1 January 2018),
- Directive 2004/35/CE of the European Parliament and of the Council of 21 April 2004 on environmental liability with regard to the prevention and remedying of environmental damage, as amended by Directive 2006/21/EC, Directive 2009/31/EC and Directive 2013/30/EU, as adapted by Decision 2016/14/MC-EnC (deadline: 1 January 2021),
- Directive 2003/87/EC of the European Parliament and of the Council of 13 October 2003 establishing a scheme for greenhouse gas emission allowance trading within the Community and amending Council Directive 96/61/EC, as adapted by Decision 2022/05/MC-EnC (deadline: 31 December 2023),
- Directive 2001/80/EC of the European Parliament and of the Council of 23 October 2001 on limitation of emissions of certain air pollutants by large combustion plants, as adapted by Decision 2013/05/MC-EnC (deadline: 31 December 2017),
- Directive 2001/42/EC of the European Parliament and of the Council of 27 June 2001 on the assessment of the effects of certain plans and programmes on the environment, as adapted by Decision 2016/13/MC-EnC (deadline: 31 March 2018),
- Article 4(2) of the European Community Council Directive 79/409/EEC of 2 April 1979 on conservation of wild birds (deadline: 1 July 2006).

Acquis on Renewable Energy Sources

- Directive (EU) 2018/2001 of the European Parliament and of the Council of 11 December 2018 on the promotion of the use of energy from renewable sources, as adapted by Decision 2021/14/MC-EnC (deadline: 31 December 2022).

Acquis on Energy Efficiency

- Regulation (EU) 2017/1369 of the European Parliament and of the Council of 4 July 2017 setting a framework for energy labelling and repealing Directive 2010/30/EU, as adapted by Decision 2018/03/MC-EnC (deadline: 1 January 2020),
- Directive 2012/27/EU of the European Parliament and of the Council of 25 October 2012 on energy efficiency, amending Directives 2009/125/EC and 2010/30/EU and repealing Directives 2004/8/EC and 2006/32/EC, as adapted by Decision 2021/14/MC-EnC (deadline: 31 December 2022),
- Directive 2010/31/EU of the European Parliament and of the Council of 19 May 2010 on the energy performance of buildings, as adapted by Decisions 2009/05/MC-EnC and 2010/02/MC-EnC (deadline: 30 September 2012).

Continued on the next page ⇒

⇒ Continuation from the previous page

Acquis on Infrastructure

- Regulation (EU) 2022/869 of the European Parliament and of the Council of 30 May 2022 on guidelines for trans-European energy infrastructure, amending Regulations (EC) No 715/2009, (EU) 2019/942 and (EU) 2019/943 and Directives 2009/73/EC and (EU) 2019/944, and repealing Regulation (EU) No 347/2013, as adapted by Decision 2023/02/MC-EnC (deadline: 31 December 2024).

Acquis on Competition

Pursuant to Annex III of the Treaty establishing the Energy Community, the following activities are not allowed and shall be assessed pursuant to Article 101, 102 and 107 of the Treaty establishing the European Community:

- Prevention, restriction or distortion of competition,
- Abuse of dominant position,
- Any state aid which distorts or threatens to distort competition.

In particular, with regard to public undertakings and undertakings to which special rights have been granted, provisions of the Treaty establishing the European Community, in particular Article 106, shall be upheld.

Acquis on Statistics

- Commission Implementing Regulation (EU) 2019/803 of 17 May 2019 concerning the technical requirements regarding the content of quality reports on European statistics on natural gas and electricity prices pursuant to Regulation (EU) 2016/1952 of the European Parliament and of the Council, as adapted by Decision 2020/03/MC-EnC (deadline: 15 June 2022),
- Regulation (EU) 2016/1952 of the European Parliament and of the Council of 26 October 2016 on European statistics on natural gas and electricity prices and repealing Directive 2008/92/EC, as adapted by Decision 2018/1/MC-EnC (deadline: 1 March 2018),
- Regulation (EC) No 1099/2008 of the European Parliament and of the Council of 22 October 2008 on energy statistics, as adapted by Decisions 2012/02/MC-EnC, 2013/02/MC-EnC, 2015/02/MC-EnC, 2021/12/MC-EnC and 2022/01/PHLG-EnC (deadline: 31 December 2022).

The rules listed in this annex are available on the website of the State Electricity Regulatory Commission (www.derk.ba).

Additional information on the activities and procedures conducted by the State Electricity Regulatory Commission may be obtained on the website at www.derk.ba, by phone on +387 35 302060 and +387 35 302070, fax +387 35 302077, e-mail info@derk.ba or at the SERC seat in Tuzla, Đorđa Mihajlovića 4/II.

